

61  
May  
1988

elektor **INDIA**

156  
Rs. 8.00

# electronics

COMPUTER CONTROLLED SLIDE FADER



Radio communications of the future

A new multilayer process for  
integrated passive devices

Parametric equaliser

*Sumit Singh*

**Publisher:** C.R. Chandarana  
**Editor:** Surendra Iyer  
**Technical Editor:** Ashok Dongre  
**Circulation:** J. Dhas  
**Advertising:** B.M. Moha  
**Production:** C.N. Mithagari

**Address:**  
**ELEKTOR ELECTRONICS PVT. LTD.**  
 52, C Proctor Road, Bombay-400 007 INDIA  
 Telex: (011) 76661 ELEK IN

**Overseas editions:**

**Elektor Electronics**  
 1, Harisque Avenue,  
 Great West Road, Brentford TW8, 9EW U.K.  
**Editor:** Len Seymour

**Pultron Publicacoes Tecnicas Ltda**  
 Av Ipiranga 1100, 9º andar CEP01040 Sao Paulo — Brazil  
**Editor:** Juliano Barsali

**Elektor aarl**  
 Route Nationale, Le Seau, B.P. 53  
 592270 Baillieu — France  
**Editors:** D R S Meyer;  
 G C P Raedersdorf

**Elektor Verlag GmbH**  
 Süsserfeld-Strasse 25 100 Aachen — West Germany  
**Editor:** J. A. Kneppelsauer

**Elektor EPE**  
 Karaskaki 14 16673 Voula — Athens — Greece  
**Editor:** E. Xanthoulis

**Elektuur B.V.**  
 Peter Treckpoelstraat 2.4  
 6191 VK Beek — The Netherlands  
**Editor:** P. E. L. Kerensmakers

**Ferreira & Bento Lda**  
 R.D. Estefania, 32 1º 1000 Lisboa — Portugal  
**Editor:** Jorge Goncalves

**Impalek S.A.**  
 Plaza Republica Ecuador 2 28016 Madrid Spain  
**Editor:** A. M. Ferrer

**In Part:**  
 Kodotron Holdings PTY Ltd, Cnr Fox Valley Road &  
 Kiole Street Wahroona NSW 2075 — Australia  
**Editor:** Roger Harrison

**Electronic Press AB**  
 Box 63  
 182 11 Danderyd — Sweden  
**Editor:** Bill Cedrum

The Circuits are for domestic use only. The submission of designs of articles of Elektor India implies permission to the publisher to alter and translate the text and designed and to use the contents in other Elektor publications and activities. The publishers cannot guarantee to return any material submitted to them. All drawings, photographs, printed circuit boards and articles published in Elektor India are copyright and may not be reproduced or imitated in whole or part without prior written permission of the publishers.

Patent protection may exist in respect of circuits, devices, components etc. described in this magazine. The publishers do not accept responsibility for failing to identify such patent or other protection.



MEMBER

Printed at : Trupti Offset

Bombay - 400 013

Ph. 4923261, 4921354

Copyright © 1988 Elektuur B.V.



Volume-6 Number 5  
 May-1988

*Surendra Iyer*

## CONTENTS

### Editorial

All in one ..... 5.05

### Components

A new multilayer process for integrated passive devices ..... 5.21

### Computers

Computer management systems take over ..... 5.23

Second generation programmable logic ..... 5.25

PROJECT: Stereo sound generator ..... 5.32

### Test & Measurement

Dual trace oscilloscopes; a review (Part-5) ..... 5.29

### Audio & Hi-Fi

PROJECT: Parametric equaliser ..... 5.36

### Radio & Television

PROJECT: Tuneable preamplifiers for VHF and UHF TV ..... 5.44

Radio communications for the future ..... 5.48

### General Interest

PROJECT: Computer controlled slide fader (1) ..... 5.52

### Information

Telecommunication news ..... 5.17

Electronics news ..... 5.18

New products ..... 5.60

Appointments ..... 5.71

### Guide lines

Index of advertisers ..... 5.74

### Selex-34

PROJECT: Tormentor ..... 5.58

## ALL IN ONE

The age of 'two-in-one' and 'three-in-one', a combination of radio and cassette player, is being replaced by the 'four-in-one.' A wristwatch is not a mere wristwatch anymore. A Japanese firm has introduced a watch with which you can talk! The gadget can decipher your voice and understand your queries. Of course, the gadget should be made familiar with your voice so that it can synthesise the characteristic notes and use the data as a dictionary for decoding the speech.

Dr. Raj Reddy of Carnegie Mellon University, whose talk on robotics is covered elsewhere in this magazine, has gone one step further. He informs us that the Japanese technology now has the limitation that the watch cannot understand the language if someone other than the owner spoke to it, unless it is re-tuned. Carnegie Mellon has developed a technology which is 'speech-independent', meaning the gadget can understand anybody's talk.

The profound changes in the technology of computer, communication and Artificial Intelligence is bringing about a metamorphosis. Thus, the concept of a four-in-one is a distinct reality. There will be a portable electronic office. A small gadget will have audio and video facility, in addition to functioning as a computer, enabling, data, video and voice transmission.

The idea of a phone in every home will be replaced by the slogan, a phone in every pocket. This micro-gadget can store a 100 pages of a daily newspaper.

Should you think these are exotic gadgets meant only for Japan and the US, you are mistaken. As Dr Reddy predicts, low-power, battery-operated, cheap computer will dominate the future and the computer will have both speech and visual facilities enabling even an illiterate villager to use the gadget. Less sophisticated the person is, more sophisticated the machine will be.

If transistors, two-in-ones, colour TVs and electronic telephone could make inroads into our villages, the days of four-in-one computers, functioning at the village panchayat office cannot be far behind.

### **Front cover**

Experimental set-up of four slide projectors driven by the computer-controlled slide fader described in our issue.

## LAUNCH OF IRS

With the launching of the indigenously-built remote sensing satellite IRS-IA, India has joined the select group of nations, the USA, the USSR, France and Japan, in having such a sophisticated facility. India is the first developing country to have a remote sensing satellite. IRS-IA, weighing 980 kg, is the heaviest satellite to be built by India and it is her tenth one to be put in orbit.

Placed in polar sun-synchronous orbit, the satellite will cover the entire Indian sub-continent once in 22 days and help in the study of natural resources during various seasons under identical conditions. The satellite is orbiting the earth over the poles at a height of about 900 km, taking 103 minutes for each orbit.

The IRS-IA carries three linear imaging and self-scanning cameras which take pictures of 148 km-wide scenes in four different colours. The data will be received at the ground station near Hyderabad. The satellite will pass over India seven to eight times a day with each pass having a duration of five to ten minutes. The data sent down will be equivalent to some 4000 volumes of 300 pages each, roughly a good sized library of about 10,000 books each day. The National Remote Sensing Agency, Hyderabad, will receive, process and distribute the satellite data to several user-agencies within India and abroad. The IRS-IA is designed to operate for a minimum of two years. IRS data will be vital in areas like agriculture, forestry, geology and hydrology and its data would be the key element in the National Natural Resources Management System.

The satellite IRS-IA was the seventh to be launched with foreign launchers and the fourth to go up with the Soviet Union. The other three satellites which were launched from the Soviet Union were Aryabhata (1975), Bhaskara-I (1979) and Bhaskara-II (1981). The Indian National Satellites (INSAT-1A and 1B) were launched from the United States. India's first experimental communication satellite, APPLE, was launched by the European Space Agency.

## LOW-COST EARTH STATIONS

The International Maritime Satellite Organisation, Inmarsat, has approved the

trial use of limited capability earth stations (LCES) for the provision of telex services to ships and possibly other mobile units. The new stations could provide easy access to the Inmarsat satellites particularly for the developing countries and from areas where the existing telecommunications infrastructure is inadequate or traffic requirement is fairly low.

Currently operating earth stations with Inmarsat satellites are substantial and expensive installations. With large, steerable, parabolic antennas, averaging 13 metres in diameter, and the capacity to handle a large number of simultaneous voice, data and telex calls, they cost several million dollars to build. There are now 20 such stations in the Inmarsat system, owned and operated by telecommunications authorities or companies in the countries in which they are located.

The new earth station will have an antenna of less than one metre in diameter and it will handle only a single telex communication channel at a time. It will operate in effect as a ship-to-ship link, through a main coast earth station. The Inmarsat council has agreed for a lower segment charge because of the restricted requirement of LCES.

## SATCOM IN BALLOON

The National Aeronautics and Space Administration of the US will use satcoms in a space project. The Inmarsat council has approved the installation of a modified ship earth station on a high-altitude balloon.

The SES will be carried on a "Supernova long duration space balloon flight". The balloon, which will carry equipment for observation of a large supernova visible from the southern hemisphere, will use the satcom terminal for transmission of observational and navigational data through its flight. The balloon will travel from Australia to Brazil in a journey lasting seven to ten days at heights up to 40 km, an altitude at which satcoms had not been used before.

The satcom terminal is being supplied by the US firm, Radar Devices, under a contract worth 27,000 dollars. It will be a modified form of the firm's satcoms ship earth station, normally sold to ships and yachts for communications through the Inmarsat system.

The satcom unit will transmit 20 minute data stream every four to six hours via

Inmarsat satellites to computers at the University of California's Centre for Astrophysics and Space Sciences. Scientists will use the positioning data to make directional changes in balloon course, which will maximise the observational opportunities.

## EUROPORT '87

Europort '87, held in Amsterdam showed the latest developments in electronics for shipping and it was evident that movement towards electronics at sea is gathering force.

In Satellite communication, the main attraction was Standard-C which made a debut. Standard-C offers all satcoms facilities except voice over a tiny omnidirectional antenna. Thrane and Thrane of Denmark is a forerunner in this field. The firm, STC, showed a mock up of a Standard-C. Marconi was displaying its new ship earth station, Oceanray 2, which has lighter, more rigid antenna (60 kg). Its target is the yacht market.

The newly unveiled transportable version, Satpax, which is packed in two cases weighing 20 kg and 40 kg respectively also made its entry. A third case to carry the plug-ins such as computer, facsimile, and UHF/VHF patch is also provided. Airdrop cases are offered and the whole system is designed to a military specification.

On display for the first time were two public phones which Comsat is promoting for use with the Inmarsat system. A credit card phone began extended trials in 1987. Interest has already been shown by cruise ships and offshore installations. Alongside was the system without credit card slot, dial or keypad. Here the caller is automatically connected to the operator at one of Comsat's earth stations and gives a card number or home phone number debit the charges before being connected manually. A number of other value-added services were being presented by Comsat, including an electronic mailbox facility called Seabox, a packet-switching service, and a chequing facility, Cashcall, which uses a device to check a caller's account and print out a cheque for cashing on board.

## NO MORE NIGAMS

The Department of Telecommunications does not favour the idea of creating more corporations like the Mahanagar

# TELECOMMUNICATION NEWS • TELECO

Telephone Nigam Ltd. Instead, it proposes to accord greater financial autonomy and decision-making powers to telephone exchanges in major cities and towns.

The main reason for dropping the creation of nigrams for big cities is that these are major revenue earning centres. Without these centres, network of smaller cities and town, would be starved of funds. Also, the government would be saddled with loss making centres, while the revenue earning centres would be

taken away in the form of autonomous corporations.

The department is considering a proposal to set up a separate financing agency for the telecommunication sector with a view to borrowing funds from the market for the entire telecommunication sector.

## DELAY IN RAX

The scheme of introducing a rural automatic exchange (RAX) a day from April 1 is likely to be delayed by at least three months. The delay is mainly due to

the non-availability of required number of units.

The unpreparedness of the seven RAX producers who have been given licence to produce them, DOT's delay in granting environmental clearance for testing the units developed by the C-DOT and the delay in identifying suppliers of back up components were among the other causes resulting in the postponement of the scheme.

# ELECTRONICS NEWS • ELECTRONICS N

## NIC OUT OF DOE

The National Informatics Centre (NIC) of the Department of Electronics has been shifted and attached to the Planning Commission. Dr. N. Seshagiri, director-general of NIC, who was reporting to the minister of science and technology now reports to the planning minister. Subsequent to this major policy change, the DOE has been reorganised. A financing agency for electronics has been cleared by the government in principle.

The shifting of NIC from DOE was inevitable because of its growing size. About 2000 experts work in NIC which is responsible for 57 departments, in addition to advising all the state governments. The centre would bring 439 districts in the country under its satellite communication network.

The union cabinet and the Electronics Commission felt that either a separate department should be created for NIC or it should be attached to a suitable ministry. Hence, it is attached to the Planning Commission. The Planning Commission has to formulate the eighth five-year plan in a more realistic manner with data from the districts. NIC, with its vast network, will provide the input to the commission.

Following the reorganisation, DOE will have 14 divisions. The materials and components division will have three sub-groups namely microelectronics group, components group and special projects in components. The second division will be consumer electronics division. Con-

trol and instrumentation division will look after power electronics, instrumentation and capital goods. The fourth will be the computers and communication division. This division will look after software development, computer aided designs and rural information system.

Other divisions are strategic electronics, information, planning and analysis, library and publication, manpower development, industry promotion, technology development, appropriate automation promotion and microprocessor application.

## BOOST TO HI-TECH

The Department of Electronics will launch a special drive to increase investment in the high-tech electronic components sector. Despite liberalised investment conditions, the private sector failed to set up hi-tech components units, which have an export potential. Now, investments are likely to be made in the public sector.

The seventh plan envisaged a turnover of Rs. 40,000 crores in the electronics sector and components accounted for one-fifth of this. To achieve this target, an investment of Rs. 850 crores was expected in the components sector. But, private units concentrated only on consumer items like colour picture tubes and glass shell.

The DOE is now making efforts to ensure that the investments are made in areas such as manufacture of bi-polar ICs, multi-layer PCBs and surface mounted devices. State electronic corpo-

rations would be encouraged to take these areas. Banks have been advised to provide finances to manufacturing these devices rather than supporting the import of electronic goods.

The DOE has also plans to upgrade the Semiconductor Complex Ltd., Chandigarh, for which an allocation of Rs. 11 crores has been made. Emphasis will be given to products which have ready marketability and export potential. Initially, requirements of calculators and telecommunication industry will be met. The department has approved the setting up of two calculator units for manufacturing two million calculators.

## C-DACT AFTER C-DOT

The proposed Centre for Advanced Computing Technology (C-DACT) will have the development of a supercomputer within five years as its major objective. The goal is to make a machine with a peak computing power of 1000 megaflops within three years. Based on this parallel processing computer, a fifth generation computer system will be developed with a rating of one to ten million logical inferences per second (LIPS) in five years. The initial funding of the project, to be made by the Department of Electronics, is about Rs. 37.50 crores, including foreign exchange worth Rs. 12.50 crores.

C-DACT, besides the computer project, will take up commercial products such as VLSIs and chips for personal computers, advanced board level products, parallel

processing workstations and software products.

Under the Administrative control of the DOE, C-DACT will be a permanent scientific society and it will be modelled after the Centre for the Development of Telematics. Dr. Vijay K. Bhaktawar, a director in DOE, will be its first executive director. Mr. K.R. Narayanan, minister of state for science and technology, and Mr. Sam Pitroda, adviser to the Prime Minister on technology missions, will be chairman and vice-chairman respectively of the governing council of the C-DACT.

Other members of the council include Mr. K.P.P. Nambiar, secretary, DOE; Dr. Vasant Gowariker, secretary, DST; Dr. R. Narasimha, director, National Aeronautical Laboratory; Prof. B. Nag, director, IIT, Bombay; Prof. V. Rajaraman, Indian Institute of Science, Bangalore; and Dr. A. Paulraj, Defence Research and Development Organisation. The existing supercomputer project and the fifth generation computer project at various centres like IIT, Madras, NAL, Bangalore, TIFR, Bombay and C-DOT will be co-ordinated by C-DACT.

In another development, the Electronics Research and Development Centre of the Kerala government at Trivandrum will be taken over by the DOE. The ERDC will be developed as a regional centre. The DOE is taking over the centre as the state government is unable to find sufficient funds for the centre.

## MICROELECTRONICS

An empowered committee of the government of India on the microelectronics policy has suggested that indigenous designs should be protected from international competition through fiscal measures.

The committee set up by the DOE has recommended that design centres be set up with prototyping facilities near electronics industry clusters. The committee has also favoured commercial interaction between the chip manufacturing and assembly units and the industry.

The expert group has laid emphasis on improving the competitive strength of the microelectronics manufacturers by giving them fiscal support. Investors are shy of entering microelectronics, fearing international competition.

The special group was set up by the government to evolve a separate microelec-

tronics policy as this sector was not growing in the country. While microelectronic devices are used in the developed world to the extent of 12 per cent, in India it is hardly one per cent.

## NUCLEONIC WEIGHER

The Indian Institute of Technology, Bombay, has successfully tested and commissioned a microprocessor-based nucleonic weigher for use on conveyor belts to measure weight of materials like coal, coke, fertiliser, lime stone, iron ore and so on.

Conventional weighing machines using load cells encounter errors of the order of plus or minus 10 per cent. Nuweigher technique, being a non-contact method, sustains the precision on measurement over very long periods with the error not exceeding plus or minus half a per cent. This is a radioisotope device for industrial application.

The application of microprocessor has made the unit intelligent in that a single unit by suitable software can use different isotopes like cobalt-60 Caesium-137 or Barium-132, corrected for decay and print out the total weight at regular intervals on command. A single central processing unit can monitor five or more belt conveyor systems every second and log the weight.

The technology, developed by Prof. B.S. Magal and Prof. V.P. Sundersingh of IIT, Bombay, is available for commercial exploitation from the deam (R & D), IIT, Bombay.

## MANAGING TECHNOLOGY

A telephone and a television in a wristwatch, a cheap and simple computer that can be used by a villager, a machine replacing the mother's womb to grow a foetus, a dietary pill as substitute for food, a non-vegetarian tomato, produced by cloning the gene of a calf with that of a tomato—these are products of emerging technologies in the next two decades. How will a professional manager cope with this change and exploit it? The Indian Institute of Management, Ahmedabad, to mark its silver jubilee year organised a seminar entitled "Managerial Response To Emerging Technologies" in Bombay.

An expert in each field namely, Robotics and Artificial Intelligence, Electronics and Information Technology, Plastics and Petrochemicals and Biotechnology

delivered a talk.

Mr. V. Krishnamurthy, chairman, Steel Authority of India Ltd., and Technology Information Forecasting and Assessment Cell, in his keynote address pointed out that success depended not so much on the capital or hardware equipment but on the technology we possessed. Technological strength characterised the emergence of new economic powers like Korea, Japan and Taiwan. Pleading for a phased technological change with a phased upgradation of the human resources, Mr. Krishnamurthy said: "We cannot move from primitive data entry machines to sophisticated, satellite-based computer networks overnight."

The chairman of Electronics Commission opined that government should not run the industries and leave them to the private sector as the government was inherently not suitable to manage the industry. The private sector would perish if it was inefficient.

Indian industry, having enjoyed the luxury of protected environment, fought shy of facing challenges. Managers should accept new challenges and be creative as the success or failure depended on the timely action taken by them, Mr. Deodhar said.

Dr. Raj Reddy, university professor of computer sciences and robotics and director of the robotics institute, Carnegie Mellon University, said the power of computers had increased 1000-fold in the last few years. If the automobile industry had progressed at the same pace, a Rolls Royce would have become available for five dollars and it would have had a speed of 50,000 miles per hour, running 500,000 miles for a litre of petrol.

A supercomputer, now costing 10 million dollars may be available for a mere 10 dollars in the next 10 years. The technology is changing at such a fast pace, that the limits of physical laws would be reached in the next 20 years, leaving no scope for new development thereafter.

At Carnegie Mellon an automobile that drives itself is being developed. It has two stereo cameras to detect million pixels. For this computation, at least a trillion operations would be needed, coupled with 1000 computer instructions. To make the car take you to your home on its own, 10 billion operations would have to be carried out, Dr. Reddy cited as an example.

Self-operating, multipurpose micro factories will be the mainstay of industries in future. These factories, based on computers, would accept designs, get instructions through satellite and produce the goods locally. Problems could be solved by contacting the computer and experts need not fly to carry out repairs. High quality products can be made here using computer, communication and knowledge industries, employing local talent and labour. This will lead to minimal inventories, while capacity will be stockpiled.

This technology, however, may result in a social problem. Low-cost labour will become increasingly unimportant. Loss of manufacturing jobs will be likely. But, what kind of new jobs would emerge cannot be even imagined today.

Computer-aided simultaneous engineering will enhance production capability. Rapid redesigning and prototyping will reduce costs. Large automotive manufacturing companies spent 100 weeks to make a new car lamp in the US while the Japanese did it in 50 weeks. Preparation of a plastic lens for the lamp involved time consuming, tedious study. Instead of the normal six days, a computer does it in 10 hours now. Tooling for injection moulding dyes used to take six to 12 weeks in the past. Now, computer-aided design and manufacturing enables the dyes to be made in less than 24 hours.

The managerial problem now and in future will be to react to trends and customers' response quickly. The industry cannot survive if customers' need is not rapidly satisfied. This implies that customer response should be obtained almost every day. Short-cycle innovation to bring the products out quickly will become indispensable. Reverse engineering will be the strategic point in future R & D and the workforce must be suitably trained to become expert reverse engineers.

## Thirty million TDA4600s

Seven years ago, Siemens found a way of integrating the control circuit for switch-mode power supplies used in TV sets on a single 7 mm<sup>2</sup> chip. Since then, sales figures have reached 30 million for the bipolar TDA4600 and 10 million for the TDA4601 version (with extended voltage range: 80-270 V).

Its ability to produce the required voltages at varying input voltages and

loads in an economical way has made the TDA4600/4601 the unrivalled top product on the market, favoured by more than 200 customers throughout the world. An enhanced version, the TDA4605, using "Sipmos" transistors has now reached the production stage. As early as 1972, engineers at the Applications Research Laboratories of Siemens had conceived the idea of using a flyback converter as a power supply for TV sets. Until then, the standard practice had been to provide a rigid, and cost-intensive, coupling with the line frequency circuit. The introduction of the flyback converter drastically reduced the circuitry and components. The integration of the entire control circuit on the TDA4600 further simplified the power supply section in the TV set. The improved reliability of power supplies equipped with the TDA4600 is reflected in the significant reduction in TV set failures over the past several years.

## New VME board from National

National Semiconductor have introduced a high-performance 32-bit board-level system based on the company's new NS32532 32-bit microprocessor, and is compatible with the widely used VMEbus standard.

The new system, the VME532, can execute up to 10 million instructions per second (MIPs), the highest performance available in VMEbus CPU at present. The VME532 is an ideal solution for systems integrators building UNIX Systems V-based multi-user systems (64 to more than 200 users). It is also well-suited for high-performance board-level embedded control applications such as automated test equipment, factory automation (robotics and machine vision), imaging applications, and aircraft flight simulators.

## Electronic fingerprint recognition

An electronic fingerprint recognition system developed by scientists at Edinburgh University's electrical engineering department has received £500,000 backing to build a full-scale demonstrator and carry out field trials.

The system was invented by the department's Professor Pete Denyer and a prototype has already been built and tested. Potential applications for the device, which electronically matches a

presented fingerprint against a memory store of "authorized" prints, include door and computer systems security and point of sale machines.

Initial development work was supported by the Quantum Fund, which is backed by the British Linen Bank, the Scottish American Investment Company, and Edinburgh University to provide venture capital for commercially exploitable work at the university.

Quantum will provide further capital to enable the university team to build a full-scale demonstrator of the device. This will then undergo field trials with De La Rue Company, who will have exclusive rights to the technology.

## Linear IC Data book

Now available from the House of Power is the Unitorde Linear Integrated Circuits Data Book for 1987-88, a comprehensive guide to the functions and applications of the Unitorde ranges of power, control and interface circuits. Products covered in the book include power-supply circuits, motion-control circuits, power-driver, and interface circuits.

**House of Power • Electron House • Cray Avenue • ORPINGTON BR5 3AN • Telephone (0689) 71531.**

## SEMI optimistic for 1988

Semiconductor Equipment and Materials International (SEMI), the trade association for the semiconductor equipment and materials industry, has predicted a much improved 1988 for its members.

SEMI's data collection programme represents input from more than 200 members around the world. Figures show an escalating backlog, as orders steadily rise and drive a positive book-to-bill that reached 1.18 in the 3rd quarter of 1987, up from 0.91 in the 4th quarter of 1986.

This optimistic attitude was initiated by strong worldwide semiconductor device shipments, reported by the Semiconductor Industry Association (SIA), which topped \$3 billion in September last year, up from \$2.5 billion for the same month in 1986.

**SEMI European Secretariat • CCL House • 59 Fleet Street • LONDON EC4Y 1JU • Telephone 01-353 8807.**

# A NEW MULTILAYER PROCESS FOR INTEGRATED PASSIVE DEVICES

by Dr. Gordon R. Love

This article describes a new process, derived from techniques used to produce multilayer ceramic capacitors, which is the key to a technique, known as Multilythics®, allowing complex integrated multi-functional passive circuits to be produced.

## Introduction

There are two fundamentally different build-up processes for multilayer ceramic devices or assemblies. Each begins with a slip of finely divided ceramic particles dispersed and suspended in a complex organic system. In the more commonly used process, this slip is cast in thin sheets of controlled thickness and dried; patterns are then printed on it by thick-film silk-screen processing, and the array of finished devices is assembled by stacking and laminating these single sheets. This process is generally known as dry stack or 'tape' manufacturing. The alternative process involves casting the slip onto an inert carrier, drying it, printing the patterns by thick film processing, and then casting the next controlled thickness layer *in situ*. This build-up process is then repeated as many times as is necessary. This technique is known as wet stack or 'paint' processing.

These two manufacturing processes cannot easily be compared, as each has its own strengths and weaknesses. For example, single sheets can be inspected and discarded if found defective in the tape process, whereas in paint processing this is virtually impossible. On the other hand, tape processing requires high precision at two distinct processing steps (printing and stacking), whereas paint processing requires high precision only at the printing stage.

## Process differences

For both manufacturing processes, a minimum amount of organic binder is required both to encourage device formation and to facilitate the eventual binder removal. Binders free of metallic contaminants are preferred because they are less likely to contaminate the ceramic formulation, and they should be removable completely and easily because they must not distort the ceramic or

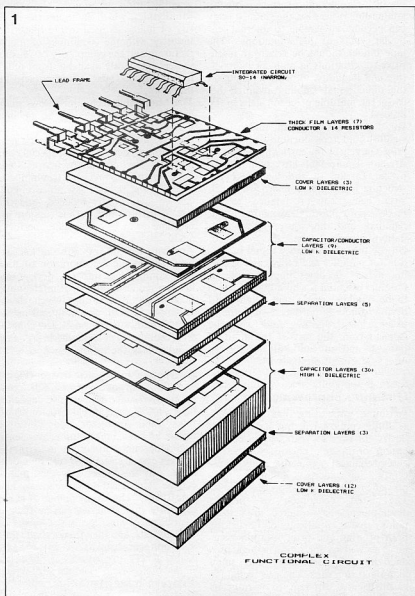

Fig. 1. Cross sectional schematic of a Multilythic device.



leave refractory residues which might interfere with the sintering process.

These binders and the associated solvents should be cheap, non-toxic, and easy to dry without film formation or cracking; moreover, the binder for the ceramic powders must be compatible with the (usually different) binder selected for the metal powders.

For a tape-based system, the organics must have excellent strength because the tape is handled as a self-supporting sheet for at least part of the process. In addition, many variations on the tape process involve locating the tape for printing or laminating (or both) by mechanically contacting the tape itself. Hence, reference holes must be both well defined and dimensionally stable.

In what appears to be a relatively fundamental conflict with these requirements, the tape has to be sufficiently plastic to permit very-high-quality lamination; otherwise, the sintered body can become vulnerable to internal lenticular voids or 'delaminations'. The tape binder should be relatively insensitive to variations in ambient temperature and humidity, in order to maintain the dimensional stability required between the multiple precision steps in the process.

For a paint-based system, dimensional stability and reproducibility are determined largely by the carrier plate, and all strength requirements are essentially met by the carrier. In addition, since the structure is assembled *in situ* with each layer being solvent bonded to its predecessors, plastic deformation is not required, and this source of 'delaminations' does not exist.

On the other hand, since visual inspection for pinholes and other casting/drying defects becomes impracticable, it becomes essential for high-quality layers to be obtained every time. High-speed drying is more important in this process because paint drying cannot easily be isolated from the rest of the build-up process, and so can limit production rates and overall productivity.

## Quantum improvements

Wet-build processing has been successfully employed in the capacitor industry for over 25 years, and a combination of organic chemistry expertise and mechanical engineering skills has recently introduced quantum improvements to the basic process.

The latest generation of process developments has resulted in a technology that is specifically optimized for both printing and print location accuracy, as well as for uniform high productivity for both large and small manufacturing runs. The new technique is sufficiently different to warrant its own name: P-4 (for Precision Paint & Print Process) manufacturing.

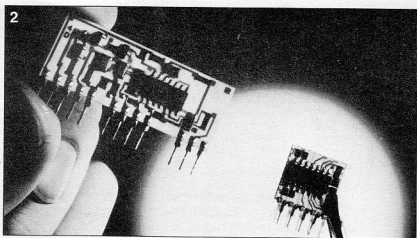

Fig. 2. Typical Multilythics devices.

This new process is crucial to a new manufacturing technology, known as Multilythics, which combines the diversity of materials used in the thick film industry with the economics of manufacturing and the complexity of finished devices inherently available from multilayer ceramic capacitor manufacturing processes.

The Multilythic technique allows many different passive functions to be integrated into the device 'substrate', so that the exterior surface of the device need only support active devices, special components like crystal oscillators, and devices requiring precision trimming. As a result, the size of assembled circuits can be significantly reduced, and this size reduction also offers major improvements in high-frequency performance.

Another benefit of this technology results from the incorporation of multiple components into the device, and hence a reduced number of interconnections which, in turn, improves the device reliability through assembly and in service. In addition, the small size, coupled with economies of manufacturing scale, should make the technology cost effective.

A typical Multilythics device (Figs. 1 and 2) incorporates low-K dielectric cover layers, high-K dielectric capacitor layers, low-K capacitor conductor layers, thick film conductor and resistance layers, and semiconductor components. The proprietary materials used in the process can be sintered to very high densities, and their electrical performance can be established very accurately and consistently. The large number of layers used in a typical device can be stacked with excellent precision in the 'green' or unfired state, and then fired a single time with uniform shrinkage.

## Process benefits

The high dimensional stability and high yields produced by the P-4 process are

absolutely essential to the Multilythics concept. Because a Multilythics device is an array of components rather than a discrete device, the whole array must be discarded if a single component in the array is defective. Hence, if array yields are to be acceptable, single component yields must be very high.

By way of illustration, if the component yields are 95%, an array of 100 components would have a yield of 0.59%; a 99% component yield would improve the array yield to 36.6% etc. The P-4 process has been found to lead to satisfactory yields.

Another benefit of P-4 assembly is modularity. Historically, a major limitation of wet-build processes has been their relative inflexibility. Where unit volumes allow the assembly process to be run at its optimum throughput, it can be extremely productive, and efficient in both labour and capital investment. However, small runs can be made only by 'idling' major components of the manufacturing line for significant lengths of processing time.

By re-configuring the assembly equipment into smaller process modules, the P-4 process allows manufacturing to take place at constant labour and capital productivity over at least a 4:1 ratio of batch sizes. This is a particularly important change in the context of the market for which Multilythics is intended, since a contributory factor to the relatively high costs of hybrid thick film manufacturing has been the difficulty in achieving meaningful automation for small manufacturing runs.

The P-4 assembly process has been tightly integrated with a computer aided design facility so that customers can design their own devices and obtain a manufactured product in a relatively short time.

Dr. G.R. Love is Vice President of Technology, Sprague Electric.

# COMPUTER MANAGEMENT SYSTEMS TAKE OVER

by James Lock

The second half of the 1980s is witnessing the full flowering of fourth generation interactive computer systems, the integration of batch with continuous control, and a trend towards the location of intelligence close to plant of equipment under control.

Several companies in the United Kingdom are investigating the application of expert systems to process control, and software systems such as Auditor from Energy Efficiency Systems<sup>(1)</sup> are emerging by which plant data can be transferred, via a company's mainframe computer, into accounts and costing systems or into sales forecasting and business planning software. An important new control system, introduced this year by Ferranti Computer Systems<sup>(2)</sup>, is the PMS 100. Ferranti describes it as an integrated, fully distributed process control and information system for supervisory and direct control, for continuous, sequence and batch control, and for high availability configurations.

It is a far cry from the process plant computer control system installed by Ferranti in 1962 for control of a soda ash plant at ICI's site in Fleetwood. Believed to be the first in the world, that had a program of only 1200 words.

Computing cards of various performance, all based on the Ferranti Argus 700 family of processors, are now used at various locations. Computing power varies from 700 000 inputs per second to more than two million inputs, depending on the configuration.

PMS 100 is a natural development of the first PMS — process management system — installed for the Bayer company at Leverkusen, Federal Germany, in 1975. Over the years, Ferranti technology has been applied in areas ranging from steelworks to radio astronomy.

## Making modifications

The data highway, Systembus SB10, is an open system based on international communication standards able to connect to other manufacturers' equipment. In a dual configuration, System SB10 data highways are treated identically. There is no master and no standby, messages are simply transmitted down a free data highway with the advantage of allowing twice the bandwidth in normal

operation. A combination of System SB10 and Ferranti's wide area network X.25/F-NET provides a communication capability for any size of PMS 100 network.

PMS 110 is a dedicated process controller that incorporates mixed sequence and continuous control facilities. Normally mounted close to the plant under control, it can be interfaced directly to it or through loop controllers and programmable controllers.

A process engineer can modify and develop new control schemes from either a terminal at the process management information system or on a portable Accessway 110 programmer located, say, in the engineer's office.

The PMS 105 device gateway allows any make of process control or operator device to be integrated into PMS 110, permitting any make of programmable logic controller (PLC) or single loop controller to be specified.

## Familiar engineering terms

Batch control in PMS 110 is provided by PMS unit operations, which provides a complete batch control environment for single product, single stream and multi-product multi-stream batch processes. Typical is its use by the Pfizer company for batch processing a range of pharmaceutical processes. A number of batches can be in progress simultaneously through different process steps using the same train of equipment.

The production supervisor can redefine production routes and resources on-line, allowing multi-product manufacture with a minimum of downtime. Automatic batch scheduling permits a campaign to be set up in advance so that production is initiated immediately the plant becomes available and it is also possible to change the order of batches. Part of the PMS operations software package is Constructor (IPC) which enables the engineer quickly and simply to build up colour graphic process diagrams, graphs and logs. The PMS system's on-line development facility

uses a high level programming language which has terms familiar to the engineer and requires no specialist programming expertise.

The trend to put the intelligence of a computer control system in close proximity to the sensors and actuators of a plant rather than relying on a single, central computer is reflected in Newmark Technology's<sup>(3)</sup> Omnibus range. This stems from the Janus Project, conceived by Professor John Brignell at Southampton University for the application of advanced microprocessor technology to measurement and control.

Omnibus measurement and control systems comprise one or more Omnibus station computers acting as master station/operator interface and a number of Multipoint measurement and control computers distributed over an Omnibus network. The Multipoint units have been developed jointly by Newmark and Jeball, a company formed by Professor Brignell, while the Omnibus computers are IBM PC or compatible computers in standard or industrial packaging.

## Collaborative project

At the heart of the Omnibus concept is a powerful dual processor that implements the synchronous data link communications (SDLC) protocol. To achieve this, Newmark took the Intel Bitbus and enhanced it to handle up to 250 stations over a range of 5 km, from systems that can start with control of a single loop.

Although a personal computer (PC) is an integral part of the systems loop, the essential difference is that this computer is used simply as a central programmer and data manager rather than as a decision manager.

The majority of decisions made by the system take place at the outstations, removing the problems associated with a failure of the main computer or its communication systems. The use of a plug-in card allows control of the Omnibus network without loading the PC. The

Multiple units form the remote stations, each one designed for use in a particular application or environment — the MP100, MP200, MP300, MP400 and now the MP500.

Omnibus communications ensure the compatibility of all Omnipoint and Multipoint units to communicate via a fast multi-drop serial data highway, as well as Omnibus products from other suppliers. Since Omnibus is Intel Bitbus compatible it is a widely supported fieldbus. Moreover, gateways into the manufacturing automation protocol (MAP), direct from the host PC or via a standard interface on the instrumentation computer board, enable the Omnibus range to communicate through standard protocols in both process and manufacturing industry.

The need to combine the skills of software and process experts has formed the basis of an on-going collaboration between Biotechnology Computer Systems (BCS)<sup>(4)</sup> and the Department of Chemical and Biochemical Engineering<sup>(5)</sup> at University College London (UCL) in the development of a comprehensive fermentation management system. BCS is a member of the Porton International group of biotechnology companies that operate worldwide. UCL is one of the British Government's Science and Engineering Research Council (SERC) designated centres for biotechnology. Some 50 staff and researchers are involved and there is collaborative work with some 14 other organizations besides academic institutions and other departments in UCL on various aspects of control.

## Digital controllers

The first two products are the software packages BIO-i and BIO-pc. BIO-i is a powerful fermentation process management system, BIO-pc is a single user bioprocess management system for up to four reactors with associated on-line equipment.

The design objectives for BIO-i were to produce a single fermentation management system that would satisfy the differing needs of the fermentation plant process engineer and worker, and the research scientist. So BIO-i has been configured as a supervisory system in which distributed digital controllers associated with each fermenter are linked to the process computer. Designed for use with the Digital Systems Equipment range of computers, the package employs well proven programming languages and real time process plant databases. Mass spectrometer data is used in the monitoring of off-gases. The distributed nature of the system and the ease with which it can be configured means that new fermenters, sensors and analytical equipment are simply incorporated when they become available.

The design objectives for BIO-pc were to produce a single fermentation management system that would satisfy the differing needs of the fermentation plant process engineer and worker, and the research scientist. So BIO-pc has been configured as a supervisory system in which distributed digital controllers associated with each fermenter are linked to the process computer. Designed for use with the Digital Systems Equipment range of computers, the package employs well proven programming languages and real time process plant databases. Mass spectrometer data is used in the monitoring of off-gases. The distributed nature of the system and the ease with which it can be configured means that new fermenters, sensors and analytical equipment are simply incorporated when they become available.



The new Ferranti PMS 100.

Fresh results of the collaborative programme, such as the current work on adaptive control, can be added to the package. This has been thoroughly tested on the sophisticated range of fermenters and reactors in the UCL pilot plant.

BIO-pc is configured on an IBM-AT or compatible computer, with monitors and other peripherals, and uses the standard MS-DOS 3.1 software package operating system. Its software elements include a complete professional Smart applications package, a feature of which is a spreadsheet with graphics that can be used while the computer is data monitoring and logging the plant.

## Short payback time

Kent Process Control Systems<sup>(6)</sup> has developed integrated configurations of its originally centralised K90 computer process control system, the P4000-ICS. This interesting development, instead of the single or hierarchical configuration of the K90, permits a number of units to be linked via the peripheral highway into one integrated system.

Each peripheral highway, of which there may be more than one per system, has a maximum of eight units, up to four of which may be operator control panels and the rest control processors. The arrangement allows a system to handle different sized process control applications, besides offering a low cost entry to ICS systems. The first two ICS systems have already been supplied to a pharmaceutical company and a major steel producer.

Kent has also introduced an expert system, based on LISP and using a Picon shell, as an option with the P4000 distributed control system. The expert system is designed to simplify interpretation of the volume of data from the process variables being monitored on a medium-to-large system. The volume of incoming data is particularly high during plant changes such as start-up and shut-down procedures.

Several companies are examining the application of expert systems to process control. The first publicised success in the United Kingdom has been LINKman. The Blue Circle cement company, in conjunction with SIRA<sup>(7)</sup>, formerly the Scientific Instrument Research Association, set it up on a KPCS P4000 distributed control system. LINKman succeeded where attempts at more conventional computer process control failed. SIRA has made an agreement with Blue Circle to market the system to other cement producers. Blue Circle has also ordered five complete systems and is anticipating a payback time of six to nine months. This quick return is largely due to energy savings.

## Higher level information

In 1984, the Alvey Commission set up a number of expert system demonstration clubs in various industrial sectors. The first of these was in control instrumentation — the Real Time Expert Systems Club of Users (RESCU). The study of an expert system as an adviser on quality control at an ICI company ethoxylates plant for batch production of detergents

has recently been completed. Systems Designers<sup>(8)</sup>, the contractor for the RESCU club of some 22 members, has now initiated a further club, the Cognitive Systems Club (COGSYS), to convert the results of RESCU into a truly commercial, fully supported product. It is expected to appeal to chemical, food, pharmaceutical and other process industries, the utilities and energy sectors, and the parts manufacture and assembly industries. Members of the COGSYS club will benefit from sales of the completed product and membership is still open to companies and academic institutions.

At the end of 1986, ICI launched Auditor, its plant performance monitoring package, with the support of Britain's Department of Energy and the Chemical Industries Association (CIA). The system, the result of new thinking about the quality of management information in the production sector in the light of reduced fortunes following the oil crises, is now used in more than 60 ICI plants and is being sold to other

companies in the chemical and other industrial sectors through Industrial Energy Systems.

Auditor technology is simply a higher layer of production information and it uses existing monitoring devices and information. Linked to the company's mainframe computer system it can transfer data into the accounts and costing system or into sales forecasting and business planning software.

The package also interfaces with two higher level systems developed by ICI. Co-Auditor is designed to monitor and optimise the running of a whole site with several interacting plants, and Energy Management System is used for site or company-wide energy monitoring to allow comparisons of different periods of production with different mixes of product.

Auditor systems installed at ICI have had an average payback time of six months. A standard Auditor package consists of a DEC Micro11 computer with a winchester disk, twin floppy disks, one or two display units (normally

in colour), and a printer.

1. Energy Efficiency Systems Ltd, Midland House, 202 Linthorpe Road, Middlesbrough, Cleveland, United Kingdom.
2. Ferranti Computer Systems Ltd, Wythenshawe Division, Simonsway, Wythenshawe, Manchester, United Kingdom, M22 5LA.
3. Newmark Technology Ltd, Heathrow Causeway, 152/176 Great South West Road, Hounslow, United Kingdom, TW4 6JS.
4. Biotechnology Computer Systems, Cleveland House, Church Path, Alton Green, Chiswick, London, United Kingdom, W4 5HR.
5. Department of Chemical and Biochemical Engineering, University College London, Gower Street, London, United Kingdom, WC1E 6BT.
6. Kent Process Control Systems, Biscot Road, Luton, United Kingdom, LU3 1AL.
7. SIRA Ltd, South Hill, Chislehurst, Kent, United Kingdom, BR7 5EH.
8. Systems Designers PLC, Centrum House, 101/103 Fleet Road, Fleet, Hampshire, United Kingdom, GU13 8PD.

## SECOND GENERATION PROGRAMMABLE LOGIC

by E. Baum

The direct interface system on a microcontroller is, in principle, very similar to that on a microprocessor. In fact, there are slight differences between the individual processor manufacturers, but the applications, i.e. connection of dynamic RAMs, demultiplexing of processor buses or mailbox functions, appear to be very similar. That is why all semiconductor manufacturers offer a range of standard chips which can be connected directly to their own processors. However, there remain many more applications, where these interface modules, or even logics, i.e. latches or other TTL logics, must be added. For this, discrete logics in the 74xxx series are often relied upon. PLAs and EPLDs (erasable programmable logic devices) are also frequently used.

It is now possible to imagine integrating the processor interface and the interface to the controller or processor in a single EPLD. The density of this module of up to 1800 gate equivalents is therefore quite sufficient. However, thanks to the very simple and regular structure of the bus interface, many of these gates remain unused on the chip. This essentially has two disadvantages. Firstly, the

chip could be even cheaper if the superfluous gates were totally dispensed with. Secondly, EPLDs and PLAs with large numbers of gates are slower, since the internal capacities are greater and the signal propagation speeds are slower. In some circumstances therefore it is necessary to rely on several small modules.

The new member of the EPLD family from Intel, the 5CBIC (bus interface controller), fills this gap perfectly. As the name implies, this chip offers a highly integrated solution for all designs which contain bus transfer lines or generate control signals. Even the driver, which in some cases still has to be provided in a bus interface, can more often than not be dispensed with when the 5CBIC is implemented. The maximum current on the bus side can be 32 mA. The 5CBIC thus offers all the advantages of high integration such as low space requirement, low current requirement, low system and manufacturing costs, and so on.

Figure 1 shows the basic 5CBIC design. The 8-bit wide A port on the bus management unit, BMU, lies directly on the processor or controller bus. On the

"user side" there are two further 8-bit ports, B and C. As will be seen later, these three buses are bidirectional and can be combined randomly, even dynamically, with each other. The second largest block is the programmable logic unit, PLU, which contains an 8 macrocell EPLD unit. The PLU has 8 dedicated inputs and 8 bidirectional pins. Both blocks can be supported via the control unit.

### Bus Management Unit

The bus management unit links ports A, B and C together and controls and monitors the data flow over their lines. At the same time, the user can choose whether the data flowing into these ports is to be latched or not. For this a latch enable signal can be generated in the PLU or supplied directly via a pin. Various EPROM cells, or dynamically modifiable signals generated by the PLU, control the data flow. Each port can also be connected with any other. Depending on the requirements or the subsequent hardware, the signal can be given out on one of the outputs inverted or directly. Three signals generated in the

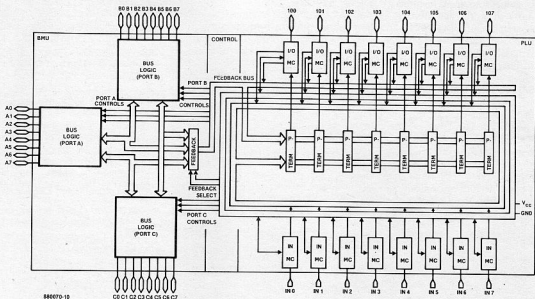

Fig. 1. A Bus Management Unit (BMU) and a 5C060 step-up compatible programmable logic unit (PLU) conventionally connected and manually optimized with the flexibility of programmable logic.

PLU can be sent by the output buffer to the ports in the high resistance state, in order that data may then be received there. A multiplexer can make the signals from a port, latched or not, available to the PLU AND/OR array. The connections between the three ports on the BMU itself, are programmed via EPROM cells (Figure 2).

and C. The driver current of 32 mA per pin should be sufficient for most applications. The working frequency of the external logic can be up to 12.5 MHz. Internally, the 5CBIC can work with up to 20 MHz. The PLU can now "observe" the data or address flow and chipselects, generate other control signals or simulate an additional parallel port.

application (Figure 3). Eight dedicated input pins and 8 bidirectional pins can be connected to the macrocells. Considering that data from ports A, B or C can also be obtained via the internal feedback bus, the user has up to 24 inputs, and up to 8 outputs available per product term.

As has already been seen with the EPLDs and PLAs logic operations, sequences are firstly converted into an AND/OR structure, which is usually generated and optimized by the development system, IPLDSII (Intel Programmable Logic Development System, version 2). This structure can then be very easily implemented in the AND/OR array on the input of a macrocell as a so-

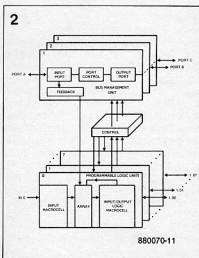

Fig. 2. The data flow can also be configured dynamically.

Consider the connection of the 5CBIC to, for example, an Intel controller in the MCS 51 family. Then, using the BMU, it is possible to demultiplex the address and data bus and make the rest of the circuit available separately on ports B

## Programmable Logic Unit

The second large block on the 5CBIC chip is the programmable logic unit, PLU. This essentially has a 5C060 EPLD superset. Eight macrocells can, with the help of EPROM cells, be adapted to the

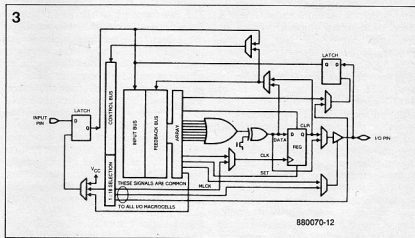

Fig. 3. The 5CBIC macrocells — I/O latches and high driver currents — make the use of the processor bus an optimal application.

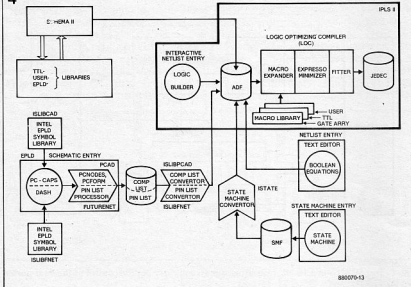

Fig. 4. The IPLDSII allows the use of TTL, gate array, and user-defined symbol libraries.

called sum of products. Each macrocell always has available the 8 dedicated input signals, the 8 macrocell feedback loops, the 8 signals on the bidirectional pins, and the signals on one of the BMU ports. Since all signals are dealt with directly and inverted on the AND/OR array, any combination can be programmed by setting the corresponding EPROM cells. As opposed to the 5C060, each input signal can be individually latched. The only exception are the 8 bits which come from the BMU. These may only be latched together, or not at all. The latch enable signal for each input latch can either be generated individually with the help of a product term or by a common control signal.

Behind the OR gate, which can comprise eight product terms, there is an inverter whose optimum algorithm (Espresso Minimizer) makes life a little easier, since it allows DeMorgan's theorem to be reproduced in the hardware. The consequent I/O section of the macrocell is therefore very like that of the 5C060 (Figure 3). Combinatorial or register logics can be created here. With register logics there is a choice of four registers. Depending on what is most suitable for the application, either a D-, toggle-, JK- or RS-flipflop is used. Whereas when using a D- or toggle-flipflop all eight product terms are connected to one input, with the RS- and JK-flipflops the product terms are shared arbitrarily between both inputs. Each register in the I/O part of a macrocell has a set and a clear input which are controlled via one of its own macrocells.

The clock signal, the latch-enable and the output-enable signals can be individually selected for control between either the control bus (synchronous) or a product term (asynchronous). This also

gives greater flexibility in comparison with the macrocells of, for example, the 5C060.

The output of a macrocell can be fed back into the AND/OR array via either the control- or feedback bus. This signal is picked off before the tristate buffer in the cell's output. Behind the buffer, and thus physically linked with the I/O pin, there is a second pick-off. If, therefore, the variable generated by the macrocell is only needed internally, it can be further used as input if the buffer has to be switched to high resistance. Using this dual feedback option, it is very simple to generate the so-called buried registers. The development system keeps these functions transparent for the user.

## IPLDSII: expansion of the development system supports the 5CBIC

On many points, the development systems of the EPLDs have been improved with the IPLDSII (Intel Programmable Logic Development System, Version II — Figure 4). The new hardware is now based on the Intel Programmer IUP-PC. Apart from EPLDs, all other EPROM-based modules, EPROM microcontrollers, etc. can also be programmed.

More important though for daily working with EPLDs are the changes in the software. So a new algorithm for optimization (Espresso Minimizer) was implemented. For large EPLDs in particular, important improvements were made in the design density. The fitter, and thus the program part, which assigns a design for optimization of the macrocells in the selected EPLD, has also been improved.

Working with the IPLDSII has also been simplified considerably and made more comfortable. Although previously it was possible to use modular design methods and link together several source files, now it is possible to go even further back to the design macros. The macro-library comprises three blocks:

- TTL macro-library
- Intel Gate Array Library
- User-defined library

The TTL library comprises a collection of the most-used modules in the 74 series. The user enters the modules with the corresponding connections to the remainder of the logic. The macro-expander then converts this information into EPLD primitives which are reunit

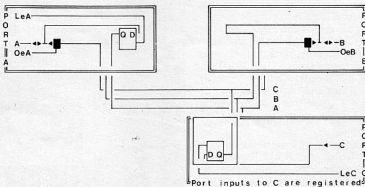

880070-14

Fig. 5. With the aid of the IPLDSII, the 5CBIC bus management unit can be configured very easily.

in the minimizer. The expander also recognizes if a chip is not being fully utilized and erases the remaining gates. So, for example, if with the 7400 only 2 of the 4 gates are used, only 2 will be implemented in the EPLD.

Sometimes it is possible to use EPLDs as prototypes or backups for a gate array design. In order to make this as simple as possible, Intel has grouped the gate-array macros in a further library, which can be implemented in an EPLD.

Of great interest, of course, is the possibility, with the help of a few utilities, for the user to create a library himself, the elements of which can also be made up of those of the other two, i.e., the TTL library.

As with the old version of the IPLDS, for documentation an advanced design file (Netlist File), a logic equation file with the actually implemented and optimized functions, and a report file with the utilization and pin assignment of the EPLD is generated. If during compiling errors are found, the messages are "collected" in an error file.

In the software output, a JEDEC-compatible file is generated which serves as input variable for one of the programming units, from Intel or another, which support the EPLDs.

The basic version of the IPLDSII supports the circuit input with the help of an editor. It is however simpler to use the logic builder which allows interactive graphically-supported conversion of a circuit diagram into a netlist. The logic builder also makes configuring the 5CBIC bus management unit very simple. A BMU block diagram comes up on the screen (Figure 5). Using the cursor, it is possible to "go into" the desired block, i.e. the block for port C. By simply pressing the "RETURN" key, it is now possible to select from all the configuration possibilities. The respective functionality is entered on the circuit diagram on the screen as are the connections to the other ports. Later the output enable (Oex), latch enable (Lex) or select (Selx) signals are connected. The signals can be connected directly to pins or controlled from one of the macrocells. The compiler takes care of the allocation.

In order to simplify input, various software packages expand the IPLDSII. ISTATE for example allows input of state diagrams and truth tables. Further library and conversion packages allow circuit diagram input using PCAD or DASH.

Since the middle of 1987, Intel has also been offering an IPLDS-compatible software package for circuit diagram input, which is reasonably priced. SCHEMA II, as the package is called, is produced by OMATION and sold by, amongst others, Intel. In addition to their own schematic capture software, some libraries contain EPLD primitives and 74xxx symbols, which can be sup-

6

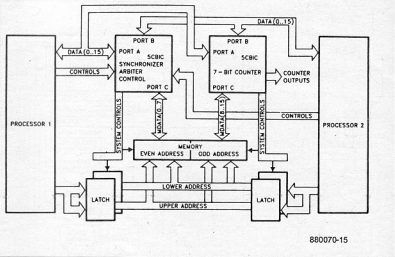

Fig. 6. Two 5CBICs in a 16-bit, twin-processor system carry out the control of the dual-ported RAM.

ported by the IPLDSII. The circuit diagram can now be input and advantage taken of the SCHEMA software, i.e. by plotting on simple EPSON printers or HP LASERJET, and even on plotters working with larger than A4 format. The circuit, which may, of course, contain TTL symbols, is converted into an advanced design file, which then serves as input to the IPLDS compiler. The design is minimized and then fitted into

the EPLD selected. In addition to the plot files, the same output files are generated for documentation as when the logic builder is used. In addition SCHEMA II offers a range of other aids. Thus, it is possible for the user to automatically create parts lists, carry out a design rule check, check routing, and print out various data formats, pinlists, netlists, and so on.

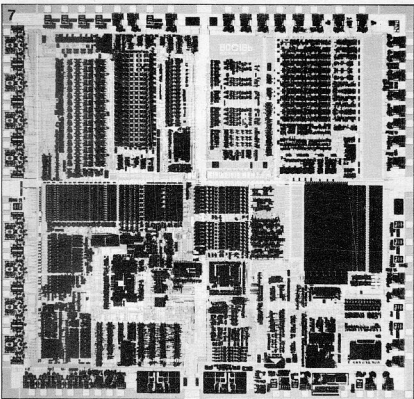

Fig. 7. Photograph of the experimental set-up of Fig. 1.

## 16 Bit dual port memory

A popular way of making computers faster is to have several processors working in parallel on a single task. Here, the processors must from time to time exchange data for synchronization and management from shared memories. This exchange takes place more often than not via a dual-ported RAM. The

logic, which is necessary for managing such a RAM, can now very easily be created with the help of two EPLDs of the 5CBIC type (Figure 6). Here, two 16-bit processors are accepted which can access a joint memory bank. Each 5CBIC can work with an 8-bit width. Two are therefore required. The first module manages the upper 8 bits of the

databus. It also takes care of arbitration. The second manages the lower 8 bits. In the PLU, a 8-bit counter is implemented which is required in other parts of the application. Further information is available from Intel in the form of applications leaflets.

*Eckart Baum is with Intel, Munich.*

# TEST & MEASURING EQUIPMENT

## Part 1: dual-trace oscilloscopes (E)

The final article in Julian Nolan's review of dual trace oscilloscopes deals with the Hung Chang OS-635.

The Korean company of Hung Chang is, perhaps, better known for its range of DMMs, frequency sources, and counters, some of which are sold under a variety of retail trade names.

The Hung Chang OS-635 is a 35 MHz delayed sweep oscilloscope with a 6 kV CRT retailing at £399 (excl. VAT), which is only about £80 more than one would expect to pay for a 'basic' 20 MHz model.

The delayed sweep is of the 'coarse' variety; the instrument is also fitted with trigger hold-off and single sweep modes. The OS-635 is fitted with a standard IEC mains socket. The line voltage is externally adjustable to 100, 120, 220, or 240 VAC.

The instrument is not fitted with a swivel stand, but the single position stand provided instead allows easy stacking of the unit.

The OS-635 is of average depth and width: 352 mm and 294 mm respectively, but its height of 162 mm is perhaps rather more than might be expected.

Two high-quality probes (1.4 ns rise time when in 10:1 attenuation mode) are supplied as are accessories for use with them, including a BNC adaptor and spring-loaded clip.

**Front panel.** The front panel is probably one of the OS-635's most distinguishing features, with colour-coded sections such as triggering and Y-amplifier functions. Although the colour coding adds to the ease of operation, the panel is not,

as common, anodised, but the markings have been printed on. This, together with the exposed potentiometer bushes of some controls, gives the instrument a rather rough and ready appearance. However, this certainly does not mean that it is of low quality.

**Y-amplifiers.** The attenuation coefficient of both Y-amplifiers is variable over a range of 10 V/div to 5 mV/div. In addition to this, a  $\times 5$  magnification facility is also available, enabling maximum sensitivities of 1 mV/div to be achieved.

Undoubtedly, one of the main features of the OS-635 is its 35 MHz bandwidth.

This is maintained down to 5 mV ( $-3$  dB). The 1 mV/div sensitivity brings with it the restriction of a 10 MHz bandwidth (rise time 35 ns).

Both Y-amplifiers have a continuously variable attenuation control, which increases the maximum attenuation coefficient to 30 V/div. Only one channel can be inverted.

The performance of the Y-amplifiers is reasonable in terms of frequency response and bandwidth, given their relatively high frequency range. But, despite these mediocre characteristics, they are still undoubtedly better than the average 20 MHz Y-amplifier at this price level.

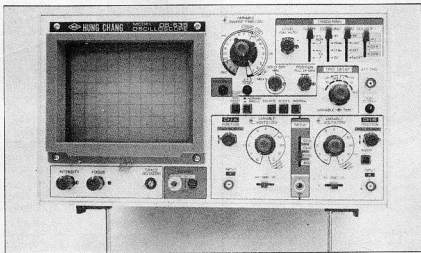



**Table 17.****ELECTRICAL CHARACTERISTICS**

line voltage: — 100, 120, 220, 240 VAC  
 $\pm 10\%$ , externally adjustable. Power  
 consumption: 30 Watts  
 Line frequency: 50-60 Hz

**MECHANICAL CONSTRUCTION**

Dimensions: — W 294 mm, H 162 mm,  
 D 352 mm  
 Housing steel sheet  
 Weight: approx. 7.5 kg

**Y AMPLIFIER ETC.**

Operating modes: —  
 CH1 alone, CH2 alone.  
 Inversion capability on CH2 only.  
 Any combination of CH1, CH2 (alternate  
 or chopped (250 kHz))  
 CH1 + CH2  
 Frequency response 0...35 MHz  
 (-3 dB).

Risetime < 10 nsec, (35 nsec  $\times$  5 Mag.)

Deflection factor 10 steps:

5 mV/div...5 V/div  $\pm 3\%$ .

$\times 5$  magnifier extends range to 1 mV/div,  
 MHz bandwidth.

Input coupling: AC, DC or Gnd.

Input impedance: 1 M $\Omega$ /25 pF; max input  
 voltage 300 (DC + peak AC)

**X-Y MODE**

CH1 X-axis and CH2 Y-axis. Less than 3 $^\circ$   
 phase shift at 50 kHz  
 Bandwidth DC to 1 MHz (-3 dB).

**SWEEP**

Operating modes — normal: timebase A  
 displayed (no delay); intensified:  
 timebase A intensified by trig delay over  
 magnification area; delayed: A sweep  
 starts after delay time.

A sweep time 100 ns/div to 0.5 s/div  
 $\pm 3\%$  in 21 ranges; 1-2-5 sequence;  
 vernier control slows sweep down by up  
 to 2.5:1.

Delay time — 10 ms to 1  $\mu$ s in 5 steps,  
 1:1 sequence; variable control for fine  
 adjustment.

Sweep magnification —  $\times 5 \pm 10\%$  total  
 error.

Hold off — variable up to 10:1.

Delay modes — continuous delay.

Delay jitter — 1/5000.

Single sweep facility.

**TRIGGERING**

Trigger modes — auto and normal.

Trigger coupling — AC; DC; HF reject; LF  
 reject; TV frame and line (auto).

Trigger sources — Ch; Ch2; alternate;  
 line; ext.; ext/10.

Triggering sensitivity — internal: 1 div at  
 35 MHz; external: 0.2 V<sub>pp</sub> at 35 MHz.

**MISCELLANEOUS**

CRT — measuring area 80  $\times$  100 mm;  
 accelerating voltage 6 kV; metal backed;  
 PDA.

Compensation signal for divider probe —  
 amplitude approx. 0.5 V<sub>pp</sub>  $\pm 3\%$ ; fre-  
 quency 1 kHz.

Z modulation sensitivity — 3 V (complete  
 blanking).

Warranty — 1 year.

Despite being specified at 3%, overshoot  
 is particularly evident on some ranges,  
 although it remains within the quoted  
 limit.

The dynamic range is somewhat limited  
 at about 4½ divisions at 35 MHz, but  
 should, none the less, be acceptable for  
 most purposes.

A minor point is that the  $\times 5$  magnifier  
 has the effect of magnifying the trace  
 offset, which is set by the Y position  
 control, with the result that some repositioning  
 of the trace is required when  
 the  $\times 5$  magnifier is actuated.

Since the  $\times 5$  switches are incorporated  
 in the Y position controls, it happens  
 that when these controls are accidentally  
 turned when they are pulled out to actuate  
 the  $\times 5$  magnifier, the trace shifts. If  
 this has already been centred, an unnecessary  
 adjustment is required to re-centre it.

Chopped (200 kHz) or alternate sweep is  
 selected automatically by the time base  
 speed setting.

**Triggering.** Triggering on the OS-635 is  
 comprehensive, including LF and HF  
 filtering, alternate channel sourcing and  
 TV synchronization. In addition to this,  
 unusually for a scope in this price range,  
 an external  $\div 10$  facility is also provided.  
 The auto/normal and triggering  
 threshold controls are combined into  
 one in a similar manner to the  $\times 5$  at-  
 tenuation coefficient magnifier. Here,  
 the problems brought about by this are  
 not so acute, but still noticeable; the  
 auto position is selected with the level  
 control fully out. All other triggering  
 controls (of the slider type) are, however,  
 relatively easy to operate.

TV triggering is particularly notable, be-  
 ing selectable from positive or negative  
 synchronization and, with the inclusion  
 of automatic line and frame switching,  
 incorporated into the timebase coeffi-  
 cient selector. Triggering sensitivity is  
 also good: typically 0.2 div to 10 MHz,  
 increasing to 1 div at 35 MHz and 3 div  
 at 60 MHz, which is the maximum  
 reliable trigger frequency. External trig-  
 ger sensitivity is also good at 100 mV to  
 10 MHz and 0.2 V to 35 MHz. This can,  
 however, be increased by means of the  
 $\div 10$  control to eliminate false triggering,  
 caused, for example, by noise. An alternate  
 channel, or composite mode, is also  
 incorporated for observation of two  
 unrelated (in terms of frequency) signal  
 sources. Triggering symmetry (rising or  
 falling slope) proved to be out by ap-  
 proximately 1 division over a total verti-  
 cal deflection of 8 divisions. The HF  
 and LF facilities provided are effective in  
 obtaining a stable trace even in cases of  
 waveforms with a very high modulation  
 content, and are a further useful addi-  
 tion to the OS-635's trigger functions.  
 Both trigger and 'ready' LEDs are also  
 incorporated, lighting when the scope is

stably triggered or reset respectively.  
 Trigger holdoff is also a feature of the  
 OS-635, which makes the triggering  
 facilities provided by this scope amongst  
 the best in its class.

**Timebase.** The OS-635 is equipped with  
 a single timebase and an uncalibrated  
 vernier delay time control. This has the  
 consequence that in the vast majority of  
 situations only uncalibrated delayed  
 sweep measurements can be made of  
 waveforms which exceed the maximum  
 horizontal deflection limit of 10 divi-  
 sions. In most cases this limitation does  
 not affect the measurement of waveform  
 rise times.

The main timebase itself ranges from a  
 respectable 0.5 s/div to 100 ns/div,  
 although, obviously to limit the cost of  
 the deflection circuitry, only a  $\times 5$   
 horizontal magnification system has  
 been incorporated, increasing the maxi-  
 mum deflection speed to 20 ns/div. The  
 trigger delay time coefficient can be  
 selected from one of 5 (the front panel is  
 marked for 6) covering the range from  
 1 sec to 100 msec in a 1:1 sequence. This  
 departure from the standard 1-2-5 se-  
 quence is false economy since, although  
 it reduces the number of switch positions  
 to 5 instead of 15, highly accurate ad-  
 justment of the vernier control is re-  
 quired at higher magnification levels. It  
 also has the effect of reducing the ease  
 of use of the delayed sweep facility  
 significantly in my opinion, largely due  
 to the accurate vernier adjustments  
 which have to be made. Rise time  
 measurements would have been greatly  
 helped by the provision of a triggered  
 delay facility in addition to the normal  
 continuous mode, as well as a delay line.  
 Looking at the situation in perspective  
 however these facilities can hardly be ex-  
 pected for £399, but effective operation  
 of the delayed sweep facility without  
 them may in many applications prove ex-  
 tremely difficult. The delayed sweep dis-  
 play modes of normal, intensified or  
 delayed should be adequate for most  
 purposes.

Timebase accuracy is inside the specified  
 $\pm 3\%$  (and the rather high  $\pm 10\%$  when  
 using the  $\times 5$  magnifier). Linearity is  
 also within the quoted  $\pm 3\%$  over most  
 of the range, although it is noticeable at  
 the start of the trace over the first 1½  
 small divisions on the maximum  
 timebase speed that the deflection  
 characteristics were, to say the least,  
 non-linear.

**CRT.** The 6 kV tube enables both good  
 intensity and brightness to be main-  
 tained over the whole range of sweep  
 speeds. The CRT itself is of the metal  
 backed PDA variety and gives a good  
 performance, especially in terms of  
 focusing, which is certainly of a high  
 standard. The tube is slightly curved  
 across its face, however, and while this is

not to a great degree, and should not affect measurements, it is still worth noting. Tube geometry is reasonable, with some barrelling and pincushioning present. The tube's good performance is hindered by the lack of an automatic focusing circuit, with the consequence that any major alterations in tube brightness can cause considerable defocusing of the trace, making some form of focus adjustment essential for accurate measurements.

**Construction.** Construction of the OS-635 is poor. While mostly not of low quality, the OS-635 is in places poorly finished, with a number of sharp edges evident on the enclosure both internally and externally. Internally, masking tape and small pieces of dowelling are used to separate some of the wire interconnections, which, while perhaps not impairing the reliability of the instrument, are really unacceptable in a modern instrument.

External construction is based on a steel chassis, with two sheet steel panels enclosing the top, sides and underneath of the scope. These appear to have had little done to them in terms of machining since being originally pressed and folded since they still contain one or two sharp edges. The front panel surround is constructed from four separate pieces of aluminium with the consequence that they are jointed at each corner.

Internal construction is of a higher standard, with the high voltage and EHT supplies enclosed, and the Y-amplifiers partially screened. The scope is based around four PCBs, connections from which are all made by connectors for easier servicing and while this leads to a large number of interconnections, it

should not affect reliability. As well as being used to separate some of the interconnections, masking tape is also used around the CRT.

Overall construction both internally and externally appeared to be average in its class, and whether this will effect the reliability remains to be seen. The quality of components used is generally good and this may be worth taking into account.

**Manual.** The 30 page manual includes a full circuit and PCB layout diagrams. A full circuit description and initial set up information is also given, along with calibration and preventative maintenance sections.

**Conclusion.** Looking at the specification alone, the OS-635 appears to represent a extremely good price/performance ratio, with a 35 MHz (-3 dB) bandwidth, 6 kV PDA tube and delayed sweep facility. In reality, some of these facilities are limited in their performance, which is especially true of the delayed sweep facility, which in some situations offers little more than can be achieved with a scope that possesses a good trigger performance. Having said this, both the triggering performance and facilities offered by the OS-635 are good for a scope in its class and should not be ignored. An automatic focusing circuit is not fitted, which is unfortunate since the 6 kV PDA is capable of producing a trace of both excellent intensity and sharpness, but to maintain this without the provision of an automatic focusing circuit requires an adjustment in the focusing potential for a significant change in trace intensity. Both the internal and external construction have the appearance of a reproduction prototype rather than

a production model, but despite this there is not apparent reason why the OS-635 should not be reasonably rugged in a variety of environments. To sum up, for its specification the Hung Chang represents a very good price/performance ratio, its particular strengths lying in its 6 kV CRT and 35 MHz bandwidth. The OS-635 may well be worth considering for a large number of applications where a bandwidth of 35 MHz and high brightness tube are required on a limited budget, or as a cost effective alternative to a 20 MHz scope.

The Hung Chang OS-635 was supplied by Black Star Ltd. ● 4 Harding Way ● St. Ives ● HUNTINGDON PE17 4WR ● Telephone (0480) 62440

Other oscilloscopes available in the Hung Chang range.

**OS-615S** — dual trace 15 MHz portable; rechargeable battery operated; weight 4.5 kg; sensitivity 2 mV; maximum deflection speed 100 ns/div; 1.5 kV CRT; up to 2 hours operation from fully charged batteries; £399 excl. VAT.

**OS-620** — dual trace 20 MHz; sensitivity 5 mV; maximum deflection speed 40 ns/div; 2 kV CRT; component tester; power consumption 19 W; £295 excl. VAT.

**OS-650** — dual trace 50 MHz; sensitivity 1 mV; maximum deflection speed 40 ns/div; 17 kV CRT; delayed sweep 100 ms to 1  $\mu$ s; £579 excl. VAT.

Table 18.

CATEGORY	Unsatisfactory	Satisfactory	Good	Very Good	Excellent
TRIGGER FACILITIES					x
TRIGGER PERFORMANCE				x	
DEL'D SWEEP FACILITIES			x		
DEL'D SWEEP PERFORMANCE			x		
CRT BRIGHTNESS					x
CRT FOCUSING				x	
Y AMP ATTENUATION RANGE				x	
INTERNAL CONSTRUCTION			x		
EXTERNAL CONSTRUCTION		x			
OVERALL SPECIFICATION					x
OVERALL PERFORMANCE			x		
EASE OF USE			x		
MANUAL				x	

# STEREO SOUND GENERATOR

A high-quality stereo sound effects board for the Universal I/O bus, based on Valvo's Type SAA1099 advanced single-chip complex waveform generator. Applications include enlivening computer games and operation as a programmable test generator for simulation of composite AF waveforms.

Here is yet another simple to build extension board for the *Elektr India* Universal I/O bus<sup>(1)</sup>. It answers the popular demand for an advanced sound generator that can be programmed to produce an astoundingly wide variety of complex sounds in stereo, simply by having the computer send the appropriate commands and datawords for each channel via the Universal I/O bus. The main specifications of the sound generator board described here are shown in the shaded box below.

## Digital sound

The block diagram of the Type SAA1099 programmable sound generator chip from Valvo (Philips/Mullard) is shown in Fig. 1. The interfacing logic is shown to the left and at the top of the drawing. To the computer, the chip appears as a WOM (write only memory). Reading of the chip status is, however, possible if the processor writes copies of the commands and data into a RAM table for retrieval at a later stage. Input line A0 of the sound generator chip is made high for loading register address bytes, and logic low for databytes. The interface logic on board the SAA1099 latches the register address, obviating the need to repeat this when writing new data to the last selected register. The process of sound generation in the SAA1099 is completely digital, and based on pulse-width modulation.

Table 1 gives an overview of the function assigned to each bit in a particular register. The required octave is pro-

### STEREO SOUND GENERATOR BOARD

#### Features:

- six frequency generators  
2048 tones in 8 octaves
- two noise generators
- six tone/noise mixers
- six stereo amplitude controllers
- two stereo envelope generators
- stereo six-channel output mixer
- on-board 2x200 mW AF amplifier

grammed separately for each tone generator by writing a 3-bit number in registers 10H, 11H and 12H. The frequency range covered within each octave is given in Table 2. The frequency produced,  $f_n$ , is determined by the contents of registers 08H...0DH incl., and can be calculated from

$$f_n = \frac{8 \times 10^6}{2^{(17-0 \dots + (F-255))}} \quad [\text{Hz}]$$

(consult Table 2 for  $O_n$  and  $F_n$ ).

The contents of registers 14H and 15H determine which signals are passed by the six on-chip mixers. There are four possibilities: (1) all signals are blocked; (2) only the tone is passed; (3) only noise is passed; (4) both the tone and noise are passed. The noise generator clock rate—hence the noise colour—is individually programmable on the left and right channel by writing the appropriate data to register 16H.

Six amplitude controllers can be programmed to set the volume of the generated sound on the stereo output channels. This is effected by writing data to registers 00H...05H incl. (left: LS nibble; right: MS nibble).

The last programmable section to be discussed is the envelope generator, whose operation is best explained with reference to Table 2 and Fig. 2. In the drawing:

- (1) indicates that the output amplitude is determined only by the amplitude controller when the envelope generator is disabled;
- (2) indicates that the maximum amplitude is 15/16th of the value set by the amplitude controller when the envelope generator has been enabled;
- (3) indicates the moment when a new envelope waveform can be started by reloading E0 and/or E1.

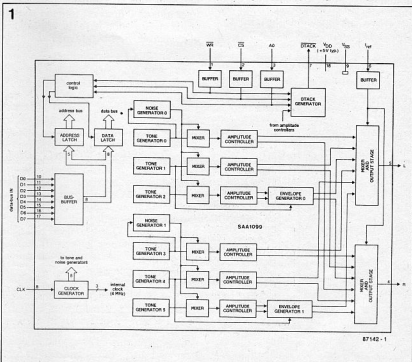

Fig. 1. Internal structure of the Type SAA1099 programmable sound generator.

Table 1.

INTERNAL REGISTER MAP										
register address	data								Function	
	D7	D6	D5	D4	D3	D2	D1	D0		
00	AR0			AL0			Amplitude 0, right/left			
01	AR1			AL1			Amplitude 1, right/left			
02	AR2			AL2			Amplitude 2, right/left			
03	AR3			AL3			Amplitude 3, right/left			
04	AR4			AL4			Amplitude 4, right/left			
05	AR5			AL5			Amplitude 5, right/left			
06	00									
07	00									
08	F0				Frequency 0					
09	F1				Frequency 1					
0A	F2				Frequency 2					
0B	F3				Frequency 3					
0C	F4				Frequency 4					
0D	F5				Frequency 5					
0E	00									
0F	00									
10	0	O1		0	O0		Octave 1: Octave 0			
11	0	O3		0	O2		Octave 3: Octave 2			
12	0	O5		0	O4		Octave 5: Octave 4			
13	00									
14	0	0	FE5	FE4	FE3	FE2	FE1	FE0	Frequency Enable	
15	0	0	NE5	NE4	NE3	NE2	NE1	NE0	Noise Enable	
16	N1			N0			Noise generator 1: Noise generator 0			
17	00									
18	E0				Envelope generator 0					
19	E1				Envelope generator 1					
1A	00									
1B	00									
1C	0	0	0	0	0	0	0	SE	Sound Enable	
1D	00									
1E	00									
1F	00									

The letters in brackets to the right of the bit combinations in Fig. 2 refer to the bit combinations in Table 2 (E0-E1; bit 1, 2, 3).

When the envelope mode is selected for a channel, the amplitude of the associated amplitude-controller is rounded down to the nearest even value (the LS bit is considered low). If, for example, the volume was set to value 1, it is rounded down to 0. An envelope generator can also function as a tone generator. If the controlled frequency channel is inactive (tone & noise generator turned off), the programmed envelope waveform will appear at the output. In this way, the sound generator board can function as a programmable waveform generator with a maximum output frequency of about 1 kHz. Faster envelope waveforms can be achieved by reducing the resolution of the envelope from 4 to 3 bits (bit 5 of byte E0 or E1). The speed

of the envelope is determined by frequency generator 1 (or 4), or by the computer repeatedly writing to the address latch, clocking the envelope generator with the WRITE signal (WS). The period of the envelope,  $t_e$ , is calculated from

$$t_e = 8/f_{\text{clock}}$$

in the 4-bit mode, or

$$t_e = 4/f_{\text{clock}}$$

in the 3-bit mode.

Bit SE (sound enable) can be used for turning the sound generator on and off. The programming of sounds is largely a matter of trial and error establishing of the required bit patterns, writing data to the chip, listening to the resultant sound, debugging the data and register selec-

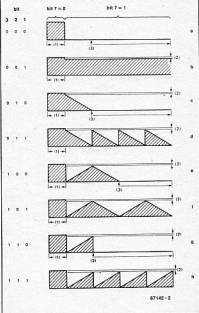

Fig. 2. Programmable envelope waveform shapes.

tions, and making the required modifications.

## Circuit description and construction

The sound generator board is composed of relatively few parts—see the circuit diagram of Fig. 3. The WR signal for the SAA1099 is made by combining R/W and  $\Phi 2$  in gates  $N_1$  and  $N_2$ . The crystal-controlled oscillator built around  $T_1$  and  $T_2$  provides the 8 MHz clock signal for the sound generator chip. The pulse-width modulated output signals of the SAA1099 are converted to analogue in R-C filters composed of  $R_1 \dots R_7$  incl. and  $C_1 \dots C_5$  incl. Integrated stereo output power amplifier IC<sub>1</sub> can provide about  $2 \times 200$  mW to the loudspeakers.

Construction of the board is straightforward, and requires no further detailing. Supply power for the sound generator board may be obtained from the computer. Due attention should be paid to adequate decoupling, however: in some cases, interference on the supply lines from the computer will necessitate feeding the board from a separate, regulated, 5 V supply (cut off pins 1 and 2 at the board side of edge connector K).

## Control software

Control programs for the sound generator board should be written with ease of register operations in mind. A simple, yet effective, way of achieving access to the registers and their contents is to

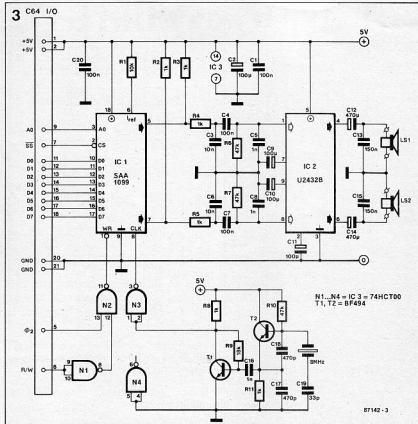

Fig. 3. Circuit diagram of the stereo sound generator board.

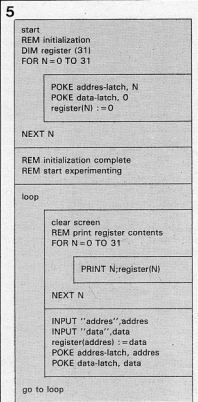
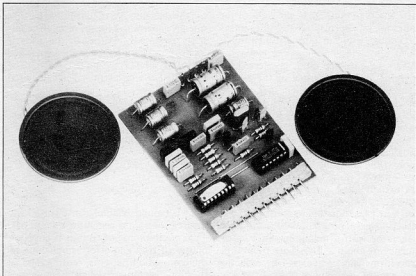

Fig. 5. Suggested structure of a control program for the sound generator board.

make use of a register selection subroutine, in conjunction with data statements and arrays. Also, do not forget to copy data written to the registers in reserved memory areas of the computer.

The program structure shown in Fig. 5 is intended as a guide for writing one's own control programs for the sound generator board. The program starts by dimensioning array variable "register".



Completed prototype of the stereo sound effects generator for the Universal I/O bus.

This array is set up to enable the computer to keep track of the data written to the registers in the interface. Next, all registers in the SAA1099, and array "register", are reset to nought in a FOR-NEXT loop. The program then enters a infinite loop for fetching register selection codes and data from the keyboard, and transferring these to the SAA1099 via the Universal I/O bus. First, the register contents are displayed on screen, so that the status of all registers is known at any time. Consecutive INPUT statements then prompt the user to enter the register address, and associated data. The program then updates the contents of array "register", and, of course, that of the addressed register. It then returns to the loop entry point.

Finally, here are two examples of sounds that can be generated by the sound effects board:

*Steam locomotive*: set AR2 and AL2 to an arbitrary value greater than 1. Set NE2=1; N0=0; E0=4. Bits and bytes not mentioned are set to nought, except, of course, the sound enable bit.

*Bell*: set the volume as required (AR2 and AL2). Set F2=FFH, O2=7; FE1=1; FE2=1; E0=4 and SE=1. Bits and bytes not mentioned are set to nought. *St*

#### Reference:

① Universal I/O bus. *Elektor India*, June 1985.

Fantasia on a MIDI theme. *Elektor India*, December 1985.

Table 2.

REGISTER DESCRIPTION	
ARx, ALx	4 bits for amplitude control of generator x, left and right channel.
Fx	8 bits for frequency control of generator x in designated octave.
Ox	3 bits for octave control of generator x. 000 lowest octave 30...60 Hz 001 50...122 Hz 010 122...244 Hz 011 244...488 Hz 100 488...977 Hz 101 978...1950 Hz 110 1.95...3.90 kHz 111 highest octave 3.91...7.81 kHz
FEx	1 bit FEx = 0 indicates that generator x is off. FEx = 1 indicates that generator x is on.
NEx	1 bit NEx = 0 indicates that mixer x does not add noise. NEx = 1 indicates that mixer x adds noise.
N1, N2	2 bits for noise generator control. These bits select the clock rate of the noise generator. 00 31.3 kHz 01 15.6 kHz 10 7.6 kHz 11 51 Hz to 15.6 kHz (frequency generator 0/3)
E0, E1	7 bits for envelope control. bit 0 0 = left and right component have the same envelope. 1 = right component has inverse envelope of that applied to left component. bit 1,2,3 000 zero amplitude (a) 001 maximum amplitude (b) 010 single decay (c) 011 repetitive decay (d) waveforms are 100 single triangular (e) illustrated in Fig. 2 101 repetitive decay (f) 110 single attack (g) 111 repetitive attack (h) bit 4 0 = 4 bits for envelope control ( $f_{max} = 977$ Hz). 1 = 3 bits for envelope control ( $f_{max} = 1.95$ kHz). bit 5 0 = internal envelope clock (frequency generator 1 or 4). 1 = external envelope clock (address write pulse). bit 6 must be 0. bit 7 0 = reset (no envelope control). 1 = envelope control enabled.
SE	0 = all channels disabled. 1 = all channels enabled.

## Parts list

Resistors ( $\pm 5\%$ ):

R1 = 10K  
 R2...Rs incl.; R6; R11 = 1K0  
 R6; R7; R10 = 47K  
 R9 = 18K

Capacitors:

C1; C4; C7; C20 = 100n  
 C3; C6 = 10n  
 C2; C8; C10; C11 = 100 $\mu$ ; 6 V  
 C5; C9; C16 = 1n0  
 C12; C14 = 470 $\mu$ ; 6 V  
 C13; C15 = 150n  
 C17; C18 = 470p  
 C19 = 33p

Semiconductors:

T1; T2 = BF494 (Cricklewood Electronics)  
 IC1 = SAA1099 (CSI Electronics)  
 IC2 = U2432B (AEG-Telefunken; Cirkit)  
 IC3 = 74HCT00

Miscellaneous:

X1 = quartz crystal 8 MHz.  
 K1 = 21-way right-angled plug to DIN41617,  
 (stock no. 471-418; Electromall 0536  
 204555).  
 LS1; LS2 = miniature loudspeaker: 8  $\Omega$ ;  
 250 mW.  
 PCB Type 87142

**ATTENTION**  
**PCBs**  
**& Set of COMPONENTS**

for projects are normally available with

**precious**<sup>®</sup> ELECTRONICS CORPORATION

52-C Proctor Road, Bombay-400 007 Phones: 367459/369478

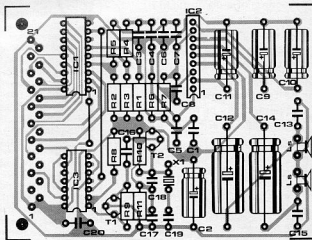

Fig. 4. Printed circuit board for building the stereo sound generator.

# parametric equaliser

A combination of state-variable filters and a highly specialised Baxandall tone control network is used in the 'parametric' equaliser described in this article, which offers considerable advantages over the more common 'graphic' equaliser. Use of a parametric equaliser allows the frequency response of a domestic hi-fi setup to be tailored to a degree previously only attainable in recording studios. Such is the versatility of a parametric equaliser that even sceptics who turn up their noses at audio equalisers may be forced to revise their opinions.

Before proceeding with a discussion of the parametric equaliser it is perhaps a good idea to discuss why it is superior to the more common 'graphic' equaliser. A 'graphic' equaliser such as the Elektor Equaliser consists of a number of band selective filters with fixed centre frequencies spaced at equal intervals on a logarithmic frequency scale, usually at octave intervals, though more expensive units may boast third-octave filters. Each of these filters is equipped with a gain control so that it can apply boost or cut to the band of frequencies over which it is active. The term 'graphic' arose from the common

use of slider potentiometers in such equalisers, whose slider position is erroneously supposed by some to represent the frequency response of the system. However, the term 'graphic' will be used to distinguish between this type of equaliser and the parametric equaliser.

The only variables in a graphic equaliser are the gains of the individual filter sections, since the centre frequency and Q (which determines the bandwidth) of each filter are fixed. A parametric equaliser has fewer filter sections than a graphic equaliser, but all the parameters of the filter are adjustable, e.g. gain, bandwidth and centre frequency. A block diagram of the Elektor parametric equaliser is shown in figure 1. This consists basically of just three parametric filter sections — band selective filters whose gain, centre frequency and Q are all adjustable. Deficiencies at the ends of the audio spectrum are catered for by a parametric Baxandall-type tone control to provide bass and treble adjustment. These controls operate in a similar manner to the parametric filter sections, but employ lowpass and highpass filters rather than band selective filters.

Figure 2 shows how the characteristics of a parametric filter section may be varied. Figure 2a shows variation of the gain, figure 2b shows adjustment of the bandwidth, while figure 2c shows adjustment of the centre frequency. Figure 3 illustrates the adjustments possible with the parametric tone controls. Figure 3a shows how variable boost and cut may be applied to the extremes of the audio spectrum, as with normal tone controls, while figure 3b illustrates the unique feature of the parametric tone controls, namely the adjustable turnover frequencies of the bass and treble controls.

Having briefly discussed the differences between parametric and graphic equalisers, the advantages of a parametric equaliser can now be illustrated. In a nutshell, the purpose of an equaliser is to make the frequency response of an audio reproduction chain flat by providing gain where there are dips in the response and attenuation where there are peaks. Figure 4a shows the response of a typical reproduction chain, as might be measured using an audio analyser. This has a number of obvious deficiencies. The 'grass' on the trace is due to a large number of sharp (high Q) resonances, which can be as

much as 20 dB deep. Fortunately these peaks and troughs are inaudible due to their very sharpness, since they each occupy a bandwidth of only a few Hz. This is perhaps just as well since it would be impossible to cancel out each of these resonances.

If this 'grass' is ignored then the response becomes something like that shown in figure 4b, in which the major deviations from a flat response are more readily apparent. It is evident that the response falls off sharply below 50 Hz and above 10 kHz, that a large peak exists at about 750 Hz and a trough at about 6 kHz.

In addition there is a slight 'ripple' in the response due to a number of peaks and troughs a few dB deep. If one accepts the fact that deviations of a few dB can be ignored (and that in any case they will be very difficult to eliminate) then the response curve can be simplified to that of figure 4c, which shows only the principal deviations from a flat response. These are the deficiencies that must be removed by an equaliser.

## Parametric or graphic?

It is fairly obvious that to remove a peak or trough from the frequency response the correction applied must be the exact inverse of the deficiency, i.e. the boost or cut applied must be the same as the depth of the trough

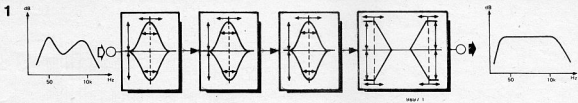

2

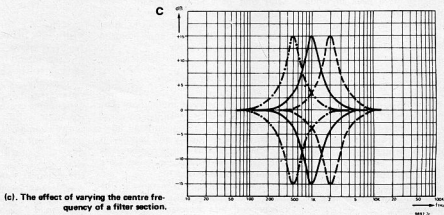
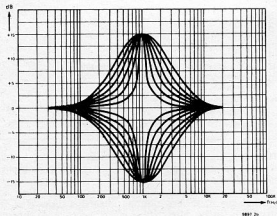
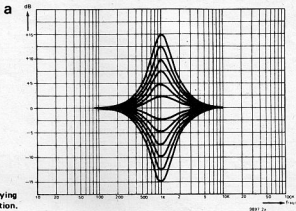
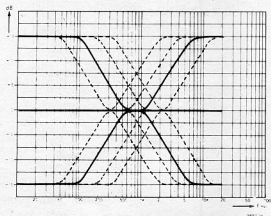
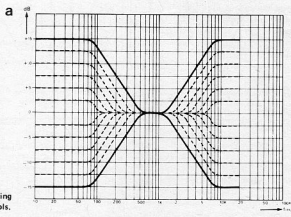



Figure 3. (a). Showing the effect of varying the gain of the parametric tone controls.



b

(b). Illustrating the effect of altering the turnover frequency of the bass and treble controls.

or height of the peak, it must be applied at exactly the right frequency, and the  $Q$  of the correction network must be the same as that of the peak or trough. It is apparent that these criteria can hardly ever be fulfilled by a graphic equaliser. Firstly, it is unlikely that the centre frequency of a peak or trough would coincide with the centre frequency of one of the equaliser filters. Secondly, since a graphic equaliser has filters with a fixed  $Q$  the shape of the filter response cannot be tailored to fit the curve of the peak or trough. In fact the only parameter that can be varied in a graphic equaliser is the degree of boost or cut. With a parametric equaliser on the other hand, the gain, centre frequency and  $Q$  of a filter section may be varied so that it is almost an exact fit for the peak or trough which it is to eliminate. At the extremes of the spectrum Baxandall tone controls with variable gain and turnover frequency can be used to compensate for the 'droop' which occurs.

Like the graphic equaliser, a parametric equaliser may have any number of

filter sections. The filter sections are necessarily rather more complex than those of a graphic equaliser; however, since each filter section is considerably more versatile it is possible to achieve satisfactory results with fewer filter sections, so that the cost is comparable with that of a graphic equaliser. For normal domestic use an equaliser consisting of three parametric filter sections plus Baxandall tone controls should be quite adequate.

#### Parametric filter section

The block diagram of a parametric filter section is given in figure 5. The heart of the filter is a selective network, which will be described in detail later, whose centre frequency and bandwidth ( $Q$ ) can be independently varied. The gain of the filter can be varied by a ganged potentiometer, P1.

The selective network is a state-variable filter or two-integrator loop, which readers of the 'Formant' synthesiser articles will recognise as being essentially similar to the Formant VCF. However,

in this circuit the centre frequency of the filter is manually controlled by a two-gang potentiometer  $R_{int}$ , whose two sections vary the time constants of the integrator stages. The  $Q$  of the filter, and hence the bandwidth, is varied by altering the values of  $R_Q$ .

#### Complete filter circuit

Figure 7 shows the complete circuit of a parametric filter section. The state-variable filter around A1 to A4 is immediately recognisable, as is the variable gain amplifier, IC1. The  $Q$  determining resistors and potentiometers  $R_Q$  become R6, R7 and P2, whilst the centre frequency is set by P3. This arrangement differs somewhat from that shown in figure 6.

However, if  $R_{int}$  were a potentiometer connected as shown in figure 6 then it would have to have an inconveniently large value if the desired tuning range were to be covered. The arrangement of figure 7 is electrically equivalent and allows the effective value of  $R_{int}$  to be

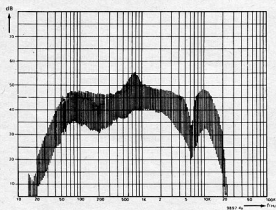

a

Figure 4. The frequency response of a typical reproduction chain, as it might be measured using an audio analyser. The 'grass' on the trace can be ignored,

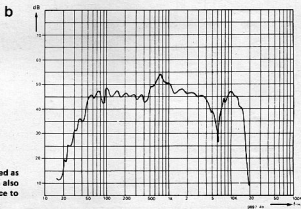

b

so that the response can be simplified as shown here. The few dB of ripple can also be ignored, reducing the trace to

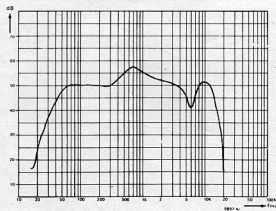

c

its simplest form. The remaining peaks and troughs in this simplified frequency response graph can be removed by using an equaliser.

Figure 5. Block diagram of a parametric filter section, which consists of a state-variable band selective filter and an operational amplifier.

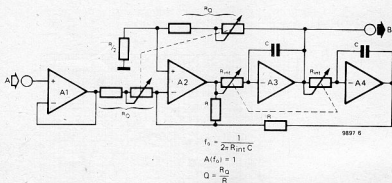
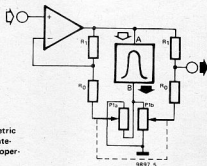

Figure 6. Circuit of the state variable filter.

varied from 10 k with P3 at maximum to about 2.65 M with P3 at minimum. This allows the centre frequency of the filter to be varied between about 40 Hz and 10 kHz. The Q of the filter may be varied between about 0.45 and 5 using P2, while the gain can be adjusted by P1 between  $\pm 15$  dB, which should be more than adequate for room equalisation purposes.

If desired the tuning range of the filter may be varied by changing the value of  $R_{int}$ , using the equation of figure 6 to calculate the required maximum and minimum values. Different components may then be substituted for P3, R12, R13, R15 and R16. The minimum value of  $R_{int}$  (P3 at maximum) is equal to R13 (R16), whilst the maximum value of  $R_{int}$  (P3 at minimum) is equal to

$$\frac{P3a + R12}{R12} \times R13,$$

similarly for P3b, R15 and R16.

The Q adjustment range may also be varied by altering the values of R8, R9, R10, R11 (= R) and R6/P2a, R7/P2b (= RQ), using the second equation given in figure 6. However this information is included only for the benefit of experimenters, and the average constructor is advised to stick to the component values given.

### Tone controls

The circuit of the parametric Baxandall bass and treble controls is shown in figure 8. This employs the same principles used in the parametric filter section. However, instead of using a band selective filter network the bass control uses a lowpass network connected between two buffers A1 and A2, whilst the treble control uses a highpass

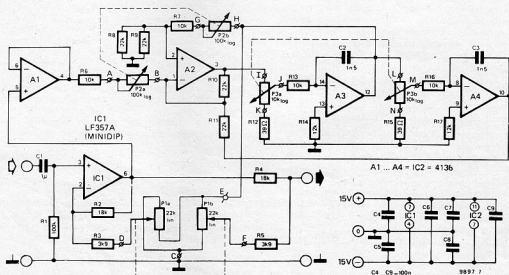

Figure 7. Complete circuit of a parametric filter section.

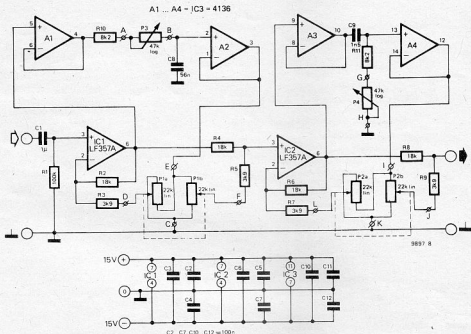

Figure 8. Circuit of the parametric tone controls. These are essentially similar to the parametric filters but use highpass and lowpass sections instead of selective filters.

**ATTENTION**

**PCBs  
& Set of COMPONENTS**

for projects are normally available with

**precious**® ELECTRONICS CORPORATION

52-C Proctor Road, Bombay-400 007 Phones: 367459/369478

Parts list to figures 7 and 9

Resistors:

R1<sup>1</sup> = 100 k  
 R2, R4 = 18 k  
 R3, R5 = 3k9  
 R6, R7, R13, R16 = 10 k  
 R8, R9, R10, R11 = 22 k  
 R12, R15 = 39 Ω  
 R14, R17 = 12 k  
 P1 = 22 k lin stereo  
 P2 = 100 k log stereo  
 P3 = 10 k log stereo

Capacitors:

C1<sup>1</sup> = 1 µ MKM, MKH (poly-carbonate, polyester)  
 C2, C3 = 1n5 MKM, MKH  
 C4, C5, C6, C7, C8, C9 = 100 n MKM, MKH

Semiconductors:

IC1 = LF 356A or LF 357A  
 MINI DIP (National)  
 IC2 = 4136 (Exar, Raytheon)

<sup>1</sup> omitted on certain boards; see text

<sup>2</sup> replaced by a wire link on certain boards; see text.

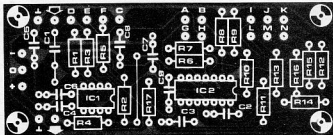

Figure 9. Printed circuit board and component layout for a parametric filter section.

**ATTENTION**

## PCBs & Set of COMPONENTS

for projects are normally available with

**precious**<sup>®</sup> ELECTRONICS CORPORATION

52-C Proctor Road, Bombay-400 007 Phones: 367459/369478

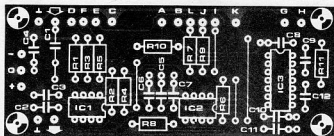

Figure 10. Printed circuit board and component layout for the parametric tone controls.

Parts list to figures 8 and 10

Resistors:

R1<sup>1</sup> = 100 k  
 R2, R4, R6, R8 = 18 k  
 R3, R5, R7, R9 = 3k9  
 R10, R11 = 8k2  
 P1, P2 = 22 k (in stereo)  
 P3, P4 = 47 k log

Capacitors:

C1<sup>2</sup> = 1  $\mu$   
 C2, C3, C4, C5, C6, C7, C10, C11,  
 C12 = 100 n  
 C8 = 56 n  
 C9 = 1n5

Semiconductors:

IC1, IC2 = LF 356A or LF 357A  
 MINI DIP (National)  
 IC3 = 4136 (Exar, Raytheon)

<sup>1</sup> omitted in certain cases; see text

<sup>2</sup> in some cases may be replaced  
 by a wire link; see text.

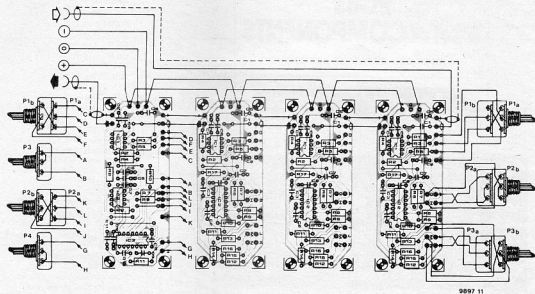

9897 11

Figure 11. Interconnection of three filter sections and tone controls to form a complete parametric equaliser.

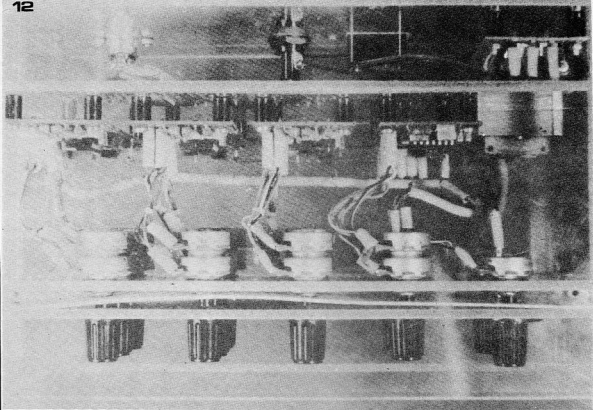

Figure 12. The completed prototype of the equaliser.

network connected between A3 and A4. The breakpoints of these filters can be varied, between 50 Hz and 350 Hz for the bass control using P3, and between 2 kHz and 13 kHz for the treble control using P4. The maximum gain of both controls can be varied between  $\pm 15$  dB using P1 and P2.

### Construction

To make the equaliser more versatile it was decided to use a modular form of construction so that as many filter sections as required could be included. This also means that the sophisticated tone control section can be used as a unit in its own right by those readers who do not want an equaliser but would like a versatile tone control system.

Each filter section is therefore built on an individual printed circuit board, the track pattern and component layout of which is given in figure 9, whilst a separate board is used for the tone controls, the layout of which is given in figure 10. The boards are so designed that, when they are stacked side by side, the output of one board aligns with the input of the next. The connection points for the potentiometers are all labelled with letters, which correspond to those printed in the circuit diagrams of figures 7 and 8.

The interconnection of three filter sections and a tone control section to form one channel of a complete equaliser is shown in figure 11. If a stereo version is required then this arrangement must, of course, be duplicated. To avoid cluttering the diagram the potentiometer connections are shown to only one filter section and the tone control section. However, connections to the other three filter sections are identical. Since the inputs and outputs of each section have the same DC potential (zero volts) the input coupling capacitor C1 and resistor R1 are required only on the board connected to the input. On every other board R1 can be omitted and C1 be replaced by a wire link. Since the zero volt rails of each board are interconnected via signal earth the '0' connection of every board except the tone control should be left unconnected, otherwise earth loops may occur. Only the '0' connection on the tone control board should be connected to the 0 V terminal of the power supply.

For the power supply the use of a pair of the commonly available IC voltage regulators is suggested. Alternatively, if the equaliser is to be incorporated into an existing system with a  $\pm 15$  V supply, then it may be possible to derive the supply to the equaliser from t.t.s.

The choice of a suitable housing for

the equaliser is left to the taste of the individual reader. One point, however, is worth noting. Adjustment of the equaliser is fairly time-consuming, but once the controls are set they should not require readjustment unless there are any changes in the reproduction chain or listening environment. It is thus a good idea to make the controls tamper-proof, for example by fitting a lockable cover plate in front of them, or by fitting spindle locks to the individual potentiometers. Alternatively the knobs could be dispensed with altogether, the ends of the spindles slotted to accept a screwdriver and the potentiometers recessed behind holes in the front panel.

# TUNEABLE PREAMPLIFIERS FOR VHF AND UHF TV

The second, final, article on remote-tuned, masthead mounted, RF preamplifiers deals with high-performance aerial boosters for the VHF and UHF TV bands. These circuits give a considerable improvement in reception compared to run-of-the-mill wideband aerial boosters. Connected to a good directional aerial, they are ideal for picking up signals that are normally noisy, or impaired by cross-modulation from strong nearby transmitters. But TV DXers need not be told . . .

The preamplifiers described can be built by anyone with reasonable experience constructing electronic circuits. Special care has been taken in the designs to minimize the necessary work on inductors, while alignment is straightforward, because in most cases it only entails setting a direct current. The amplifiers are built on high-quality printed circuit boards available through our Readers' Services, and are tuned and powered from the master tuning/supply unit described last month.

## VHF preamplifier: circuit description

What is commonly referred to as the VHF TV band is roughly the frequency range between 45 and 68 MHz (Band 1), but also that between 175 and 225 MHz (Band 3). Band 2 is the FM radio broadcast band. It is important to note here that the above band limits are given as guidance only, because they are set differently in many countries and regions in the world. This also goes for the TV system used (PAL, SECAM, NTSC, positive/negative video, horizontal/vertical polarization, number of lines, channel assignment, frequency of the sound subcarrier, etc.). In the United Kingdom, Band 1 is currently allocated to military communications; the former TV services in that band have been transferred to UHF in 1983.

The circuit diagram of the VHF preamplifier is given in Fig. 1. Unbalanced (50...75  $\Omega$ ) or balanced (200...300  $\Omega$ ) cables are connected to input inductor L<sub>1A</sub>. The aerial signal is coupled inductively to the base of low-noise RF transistor T<sub>1</sub> via L<sub>1B</sub> and C<sub>1</sub>, which is connected on a tap for impedance matching. The input inductor, L<sub>1</sub>, is tuned to the relevant TV channel by the series capacitance formed by varactors D<sub>1</sub>-D<sub>4</sub>. The voltage at the junction of these variable capacitance diodes is the voltage on the download cable minus 8.2 V. The

junction capacitance of a varactor decreases with the reverse voltage on it, so that the lowest value of the download voltage, 9 V, causes the input inductor, L<sub>1</sub>, to resonate at the lowest frequency, i.e., the preamplifier is tuned to the lowest TV channel.

The amplifier can be set up for operation in TV Band 1 or Band 3 simply by fitting the appropriate inductor in position L<sub>1</sub> (this will be reverted to under Construction).

Choke L<sub>3</sub> forms a high impedance for the amplified RF signal on the download coax cable, and feeds the tuning/supply voltage to series regulator T<sub>2</sub> and zener-diode D<sub>1</sub>. The function of these compo-

nents is similar to IC<sub>1</sub> and D<sub>3</sub> in the FM-band preamplifier described last month. The forward drop across LED D<sub>1</sub> is fairly constant, and provides the reference voltage at the base of regulator T<sub>2</sub>. Preset P<sub>1</sub> makes it possible to set the optimum collector current for the RF amplifier transistor, T<sub>1</sub>. RF signals at the base and collector of the BFG65 are blocked from the bias voltages by chokes L<sub>2</sub> and L<sub>4</sub>, respectively. Gain of the preamplifier is fairly constant at about 18 dB, both in Band 1 and Band 3. The noise figure was not measured, but should be of the order of 1...2 dB, i.e., considerably lower than almost any conventional wideband aerial booster.

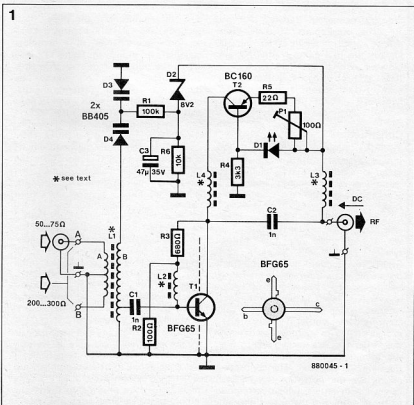

Fig. 1. Circuit diagram of the low-noise, remote-tuned, preamplifier for VHF TV Band 1 or 3.

## VHF preamplifier: construction

Commence the construction with making  $L_1$  as required for the relevant frequency range (note that this may extend beyond the indicated band limits). Do not skip the constructional hints in the following paragraphs if you intend to build the Band 1 version of the preamplifier.

### Band 3 (175—225 MHz):

1. Close-wind  $L_{1B}$  as 4 turns  $\varnothing 1$  mm (SWG19) enamelled copper wire around a  $\varnothing 6$  mm plastic former. Use a miniature screwdriver to spread the turns evenly at about 1 mm. Study the position of the inductor on the board, and bend the wire ends towards the holes provided. Use a scalpel or sharp hobby knife to remove the enamel coating on the wire ends over a length of about 3 mm. Pre-tin the connections, scratch off residual solder resin, and pre-tin once more. Check for a smooth, tinned, surface.

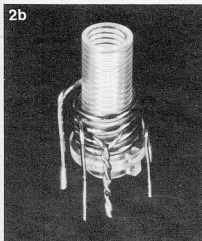
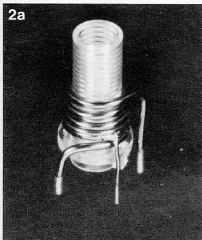

Fig. 2. Close-up photographs showing inductor  $L_1$  in the VHF Band 3 preamplifier. Fig. 2a: seen from the side of  $L_{1B}$ ; Fig. 2b: seen from the side of  $L_{1A}$  (note the tap made in twisted wire).

3

**ATTENTION**

**PCBs  
& Set of COMPONENTS**

for projects are normally available with

**precious**® ELECTRONICS CORPORATION

52-C Proctor Road, Bombay-400 007 Phones: 367459/369478

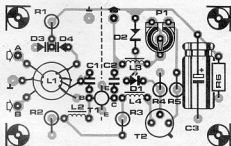

Fig. 3. The printed circuit board for the VHF Band 1 or 3 preamplifier.

#### Parts list

#### VHF PREAMPLIFIER. CIRCUIT DIAGRAM:

FIG. 1.

#### Resistors ( $\pm 5\%$ ):

$R_1 = 100K$   
 $R_2 = 100R$   
 $R_3 = 680R$   
 $R_4 = 3K3$   
 $R_5 = 22R$   
 $R_6 = 10K$   
 $P_1 = 100R$  preset H

#### Capacitors:

$C_1, C_2 = 1n0$  miniature ceramic plate; pitch:  
 5 mm.  
 $C_3 = 47\mu$ ; 35 V; axial

#### Semiconductors:

$D_1 =$  red LED  
 $D_2 =$  zener diode 8V2; 400 mW  
 $D_3, D_4 = BB405$   
 $T_1 = BFG65$   
 $T_2 = BC160$

#### Inductors:

Winding data and materials are stated in the text.

#### Miscellaneous:

PCB Type 880045



2. Locate the position of the tap on  $L_{1B}$  at 1 turn from the ground connection. Carefully scratch off the enamel locally, pre-tin the small copper area, and connect a short length of  $\varnothing 0.5$  mm (SWG25) enamelled copper wire. Place the plastic former plus inductor onto the PCB, and bend the tap wire towards the relevant hole. Do not solder any connection as yet. Make sure that the tap does not create a short-circuit between the turns of  $L_{1B}$ .

3. The input coupling inductor,  $L_{1A}$ , is wound as 2 turns  $\varnothing 0.5$  mm (SWG25) enamelled copper wire, with a tap at the centre. Wind this inductor in between the turns of  $L_{1B}$  to assure the necessary inductive coupling. Insert the wire below the turn of  $L_{1B}$  that has the tap on it. Wind the wire upwards into the free space between the turns of  $L_{1B}$ , until it is opposite the connections of  $L_{1B}$ . Draw out about 4 cm of the wire, fold it back again towards the former, and wind the last turn upwards into  $L_{1B}$ .

4. Use precision pliers to twist the 2 cm long wire pair that forms the tap on  $L_{1A}$ . Hold the end of the wires in the pliers, and carefully revolve these in your hand until the wires cross practically at the body of the plastic former.

5. Place the former with the inductors on it onto the PCB, and revolve both  $L_{1A}$  and  $L_{1B}$  until all six wires can be inserted in the respective holes. Scratch off the enamel coating from the tap and the ends of  $L_{1A}$ , pre-tin, clean again by scratching, and ensure a smooth soldering surface. Press  $L_{1B}$  together to lock up the turns of  $L_{1A}$ . The final appearance of the completed inductor is shown in the photographs of Fig. 2. Drill and file the hole that receives the plastic former. Fit the wires of  $L_1$  into the respective holes, and verify correct continuity. Do not use a core in  $L_1$ .

#### Band 1 (45–68 MHz):

For the lower frequency range,  $L_1$  is wound on a Type T50-12 ferrite core ( $\varnothing 12$  mm) from Micrometals.

1. Wind  $L_{1A}$  as 8 turns  $\varnothing 0.5$  mm (SWG25) enamelled copper wire, with a twisted centre tap created as discussed above.

2. Wind  $L_{1B}$  as 20 turns of  $\varnothing 0.5$  mm (SWG25) enamelled copper wire, with a twisted tap at 4 turns from the ground connection.

3. Fit the complete inductor onto the PCB, making sure that the windings remain secure on the ferrite ring.

Chokes  $L_2$ ,  $L_3$  and  $L_4$  are identical for both versions of the VHF preamplifier. They are wound as 4 turns  $\varnothing 0.2$  mm (SWG36) enamelled copper wire through small ferrite beads (length: approx. 3 mm).

The printed circuit board for the VHF preamplifier is shown in Fig. 3 (note that the component overlay is relevant to the

version for Band 1). Completion of the preamplifier should not present problems. Grounded component wires and terminals are soldered at both sides of the board. Coupling capacitors  $C_1$  and  $C_2$  are miniature, plate or disc, ceramic types with a lead spacing of 5 mm. Mount these as close as possible to the PCB surface. Conversely, mount  $T_2$  in a manner that rules out any likelihood of a short-circuit between the TO5 case (which is at collector potential) and the PCB ground surface. Finally, fit a 15 mm high brass or tin metal sheet across  $T_1$  as indicated by the dashed line on the component overlay.

### The UHF preamplifier: circuit description.

The circuit diagram of the low-noise, remote-tuned, UHF preamplifier for masthead mounting is shown in Fig. 4. Like the VHF booster, this amplifier is based on the Type BFG65 RF transistor from Valvo (Philips/Mullard), but in this application has tuned input and output circuits. The tuning voltage for varactor pairs  $D_1$ - $D_2$  and  $D_3$ - $D_4$  is obtained as in the FM-band and VHF preamplifiers, namely by subtracting the fixed drop across a zener diode from the

voltage carried on the download coax connected to the master tuning/supply control. The tuning range of the amplifier covers the entire UHF TV band (470–860 MHz). The shaded rectangular blocks in the circuit diagram are straight lengths of silver-plated wire that function as inductors ( $L_1$ ;  $L_2$ ). Balanced aerials or feeder systems with a termination impedance of 200...300  $\Omega$  are connected to  $L_{1B}$ . This coupling inductor is omitted when the input signal is unbalanced (50...75  $\Omega$ ). In this case, the centre core of the coax cable is connected direct to a matching tap close to the ground connection (cold end) of  $L_{1A}$ . Regulator IC<sub>1</sub> ensures that  $T_1$  is fed with a constant supply of 8 V, while  $P_1$  is used for setting the optimum collector current (this can be read on a microammeter connected to test points TP1 and TP2).

The UHF amplifier has a typical gain of 12 dB and, like the VHF version, achieves a noise figure that beats the vast majority of wideband aerial boosters.

### The UHF preamplifier: construction

The UHF TV band preamplifier is constructed on the PC board shown in

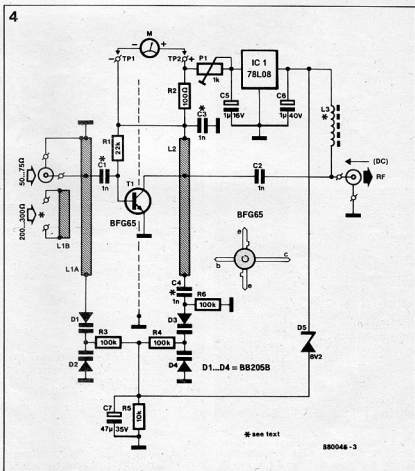

Fig. 4. Circuit diagram of the preamplifier for UHF TV reception.

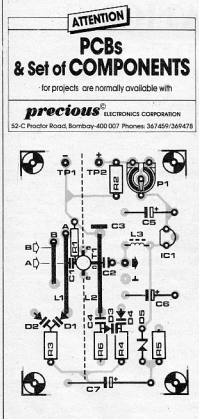

Fig. 5. Track layout and component mounting plan of the PCB for the UHF preamplifier.

Fig. 5. Study the component overlay, and bend  $L_{1A}$  (if required),  $L_{1B}$  and  $L_2$  to size from  $\varnothing 1$  mm silver plated copper wire (CuAg). Do not solder these inductors in place, however, until they run straight over the full length, and are positioned so that the top of the wire is always exactly 3 mm above the PCB surface. Fit leadless disc or rectangular decoupling capacitor  $C_3$  in the slot provided in the PCB. This (brittle!) capacitor is soldered once at the track side (connection to  $L_2$ ), and twice at the component side (ground and, again,  $L_2$ ). Now position the RF transistor,  $T_1$ , in between the wire inductors, and solder the 2 emitter terminals direct to the ground surface. Carefully bend the collector terminal upwards, cut it to length, and solder it to the tap on  $L_2$ . One terminal of coupling capacitor  $C_2$  is also connected direct to this junction, while the other terminal is secured in a PCB hole—see the photograph of Fig. 6. Bend the base terminal of  $T_1$  upwards, and carefully cut this to a length of about 2 mm. Solder a 1nF SMD capacitor,  $C_1$ , in between the tap on  $L_{1A}$  and the base terminal.  $R_1$  is also soldered direct to the base junction. Fit a 15 mm high screen across  $T_1$  as indicated on the component overlay.

Wind choke  $L_3$  as 6 turns  $\varnothing 0.2$  mm (SWG25) through a small (3 mm long) ferrite bead. The fitting of the remainder of the components is straightforward,

#### Parts list

UHF PREAMPLIFIER. CIRCUIT DIAGRAM: FIG. 3.

#### Resistors ( $\pm 5\%$ ):

$R_1 = 22K$   
 $R_2 = 100R$   
 $R_3, R_4, R_6 = 100K$   
 $R_5 = 10K$   
 $P_1 = 1K0$  preset H

#### Capacitors:

$C_1, C_4 = 1n0$  SMD  
 $C_2 = 1n0$  miniature plate ceramic.  
 $C_3 = 1n0$  leadless ceramic (disc or rectangular).  
 $C_5 = 1\mu 0$ ; 16 V; axial  
 $C_6 = 1\mu 0$ ; 40 V; axial  
 $C_7 = 47\mu$ ; 35 V; axial

#### Semiconductors:

$D_1, \dots, D_4$  incl. = BB205B  
 $D_5 =$  zenerdiode 8V2; 400 mW  
 $IC_1 = 78L08$   
 $T_1 = 8FG65$

#### Inductors:

Winding data and materials are given in the text.

#### Miscellaneous:

PCB Type 880044

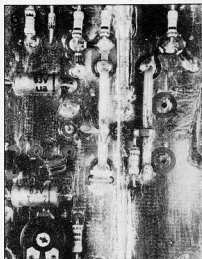

Fig. 6. Top view of the line inductors in the preamplifier for UHF TV.

and should not present problems. Be sure, however, to observe the polarity of the 3 electrolytic capacitors and the 5 diodes!

Figure 7 shows completed prototypes of the VHF and the UHF aerial boosters.

## Setting up

The setting up of the preamplifiers merely entails adjusting the collector current of the RF transistor, and finding out which value of the tuning voltage corresponds to a particular TV channel.

### VHF preamplifier:

Insert an ammeter between the collector of  $T_2$  and  $L_4$ . Connect the power supply/tuning unit described last month, and set the output voltage to 20 V. Adjust  $P_1$  for a reading of 5 mA, then verify the presence of about +11 V on the varactor junction. Vary the tuning voltage, and verify that the collector current of  $T_1$  remains constant. The LED will light dimly.

Connect the preamplifier to the aerial and the supply/tuning unit. Also connect the TV set, and set up a tuning scale by marking the channel numbers as a function of the tuning voltage. In the case of the Band 3 preamplifier, the tuning range can be corrected by carefully compressing or stretching the turns of  $L_{1B}$ .

The collector current of  $T_1$  is optimized by tuning to a weak transmission, and setting  $P_1$  for minimum noise. This setting is typically found at collector currents between 3 and 10 mA.

### UHF preamplifier:

Connect a millivolt meter to TP1 and TP2 as shown in the circuit diagram. Set  $P_1$  for a reading of 500 mV. Make notes of the tuning voltage required for a number of TV channels in the UHF

band, and provide a UHF tuning scale on the master supply/tuning unit.

### General considerations

The values stated for the operating current of  $T_1$  are given as a compromise between a low noise figure (low collector current), and high amplification in combination with good intermodulation characteristics (high collector current). The collector current may, therefore, be set to different values to suit the application in question.

As stated in last month's article, there is little point in installing the remote-tuned preamplifiers in any place other than as near as possible to the relevant aerial. This is the only way to prevent the attenuation introduced by the downlead coax cable degrading the system noise figure. The preamplifiers described have sufficient gain to bring the system noise figure down to practically the preamplifier noise figure, but only if they are properly aligned and installed. *B*

Readers interested in TV-DXing are advised to contact the British Amateur Television Club • Mr Dave Lawton G0ANO • "Grenehurst" • Pinewood Road • High Wycombe • Bucks HP12 4DD.

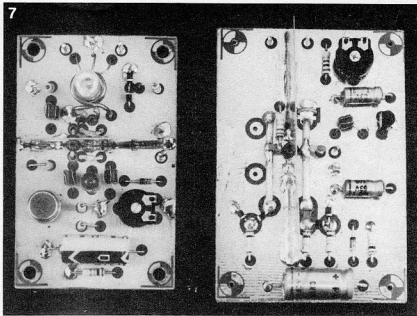

Fig. 7. Prototypes of the VHF preamplifier (left; Band 3 version), and the UHF preamplifier (right).

## RADIO COMMUNICATIONS FOR THE FUTURE

by Dr. Chris Gibbins, Rutherford Appleton Laboratory

Overcrowding of the radio spectrum is severely restricting the reliability and information-carrying capacity of existing communications systems. But moving to higher frequencies, where there is more room, brings a different set of problems to do with the atmosphere and weather. Research at the UK Science and Engineering Research Council's Rutherford Appleton Laboratory is compiling valuable data for the design of systems for the future, exploiting frequency bands that are so far little used but for which the necessary technology is already available.

A massive expansion in radio communications over recent years has generated an ever-increasing demand for more channels, and those channels are having to carry more and more information, be it voice, television or other kinds of data. The net result is that the radio spectrum, a restricted resource, is fast becoming overcrowded. This creates problems of interference between adjacent channels

(as anyone who listens to short-wave radio, especially at night, will know well) with reduced reliability. There is an additional side-effect of such overcrowding: the bandwidth available to each channel, which determines the amount of information that can be transmitted, is severely limited. That in itself restricts both the capacity and the reliability of communications systems.

### Millimetre waves

A remedy for these problems is to be found in exploiting higher and higher frequencies, made possible through the development and availability of new technologies. Communications now extend well into the microwave region of the electromagnetic spectrum (frequencies up to 30 GHz) and even beyond

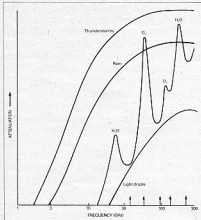

Attenuation of microwave and millimetre-wave radio signals by the Earth's atmosphere at sea level. Molecular attenuation is present all the time and is produced by water vapour (H<sub>2</sub>O) at 22 and 183 GHz and by oxygen (O<sub>2</sub>) at 60 and 119 GHz; there are many more of these 'absorption lines', mainly from water vapour, at even higher frequencies. The range of the highly variable attenuation caused by rain is shown by three representative curves for light drizzle, typical rain and intense thunderstorms. The arrows at the bottom indicate the frequencies at which the Rutherford Appleton Laboratory is making measurements.

into the millimetre-wavelength region (frequencies from 30 to 300 GHz). These regions of the spectrum are still relatively uncrowded, particularly at the higher frequencies, and the bandwidths available are so large that they open up the possibility of new communications channels with a capacity for carrying huge amounts of information.

But use of the microwave and millimetre wave regions of the spectrum for communications brings an additional set of problems not met with at lower frequencies. The Earth's atmosphere starts to interact with the radio waves, resulting in attenuation of the signals which must be taken into account in the design of systems. There are two distinct and quite different effects, which are shown in the first diagram. First, the molecules of oxygen and water vapour in the atmosphere absorb radiowaves at certain characteristic frequencies. This is known as resonant absorption. They re-radiate them isotropically, that is, equally in all directions, a fraction of a second later; this means that the signal is attenuated through the loss of directivity and coherency. The second effect is that raindrops, hail and snow scatter the signals, thereby attenuating it still more. This effect is non-resonant and increases with increasing frequency, as the wavelength decreases and becomes comparable with the sizes of raindrops; at that point the scattering process is most efficient and signal attenuation is greatest. The first effect, molecular absorption, is present all the time, and changes only slowly

with varying temperature, pressure and humidity. A great deal of research has been undertaken into this phenomenon and the effects of molecular absorption can now be predicted fairly accurately. So the designer of communications systems can take reasonably accurate account of attenuation by oxygen and water vapour when assessing the overall performance of microwave and millimetre-wave links.

## Fade margin

Signal attenuation by rain and other forms of precipitation, however, presents a quite different problem. Precipitation is a highly variable phenomenon, changing both in time, space (that is, geographic location) and intensity. This makes it much more difficult to take account of rain attenuation in designing systems. The problem is generally treated statistically instead of by the sort of exact calculation that can be used for molecular attenuation. The systems designer specifies a level of reliability for a particular communications link: for example, the link might be required to provide acceptable voice communication for 99.9 per cent of the time, or acceptable television transmission for 95 per cent. That means the users can tolerate the service being unavailable for 0.1 per cent or 5 per cent of the time respectively. The designer then needs to know what level of signal attenuation will be exceeded on the link for these small percentages of time. This is known as the 'fade margin' which the link must be able to overcome when providing an acceptable signal-to-noise ratio, to achieve the specified level of reliability. This, in turn, has an impact on the transmitter power, receiver sensitivity and the size of the antennas, which in the end affects the overall cost of the system. It is therefore of paramount importance that

the systems designer should have available the most accurate information from which to derive the necessary fade margins, to achieve the most reliable and cost-effective design.

Fade margins are not easily calculable and in general tend to be empirically derived from transmission measurements carried out over long periods. A great deal of work has already been done at frequencies up to about 40 GHz, and there are extensive data banks from which the necessary statistical information and service predictions can be derived. For example, the International Radio Consultative Committee (CCIR) at Geneva collates, distils and publishes information of this kind. At higher frequencies, however, there is a marked paucity of data.

## Foundation for systems

To provide the necessary information on terrestrial radiowave propagation, the Rutherford Appleton Laboratory has set up an experimental transmission range at its Chilbolton Observatory near Andover, in southern England. This facility, represented schematically in the second diagram, works on a number of links transmitting over a distance of 0.5 km at frequencies of 37, 57, 97, 137 and 210 GHz in the millimetre-wavelength region of the electromagnetic spectrum and at wavelengths of 10.6  $\mu$ m in the infra-red and 0.63  $\mu$ m in the visible region. Frequencies of 37, 97, 137 and 210 GHz were chosen as representative of those parts of the spectrum where atmospheric attenuations due to oxygen and water vapour are low; such parts are known as atmospheric 'windows' and hold out the opportunity for cost-effective, widebandwidth communications. The 37 GHz channel can also provide the means for comparing the results from the 500 m range with exten-

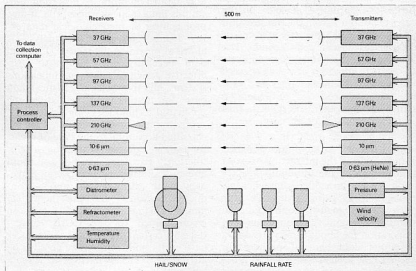

Schematic diagram of the 500 m experimental range at Chilbolton.

sive measurements made at this and lower frequencies at other places and by other workers. The 57 GHz frequency, on the other hand, is near the 60 GHz oxygen absorption band, where very high attenuations of up to 15 dB (decibels) per kilometre occur, which means 97 per cent of the signal is attenuated at a distance of one kilometre from the transmitter and only three per cent remains to be received. Such regions of the spectrum could be used for secure communications, for example where transmission range should be restricted, or for multiple repeated use of a frequency in a dense urban environment, because the atmosphere produces extra isolation between links operating at the same frequency.

In addition to the transmission links, the Chilbolton Observatory compiles a comprehensive set of meteorological data, including measurements of temperature and humidity at a number of places and heights above the ground. There are three rapid-response rain gauges, which measure the rainfall rate at different points along the range at 10-second intervals, while a fourth rain gauge is equipped with heaters to assist the measurement of snow during the winter and hail in the summer. A distrometer measures the distribution of the sizes of raindrops, important in the development of theoretical models to describe rain attenuation; a microwave refractometer measures the refractive index of the atmosphere, which affects the level of scintillation, the name given to small, very rapid fluctuations in the received signal power. The meteorological observations are completed with surface pressure and wind speed and direction.

Outputs from all the links and sensors are coupled via an interconnecting computer bus to the main data-collection computer, which records all the measurements on magnetic tape every 10 seconds. Additionally, when attenuation due to precipitation is detected on the range, the outputs from the transmission links are recorded separately at a rate of 100 measurements per second. The datacollection computer also initiates automatic calibrations of the links every 6 hours. All magnetic tapes are subsequently calibrated and verified on a main-frame computer, and the data files put into an archive for analysis.

The 500 m range, then, is a well instrumented open-air laboratory designed to study in detail the interaction between radio waves and the prevailing weather conditions, by providing comprehensive propagation data for a distance over which meteorological conditions are essentially constant. The range has been in operation for about three years and a substantial data base of propagation data has now been accumulated. It is being used for a variety of studies aimed at a more detailed understanding of the

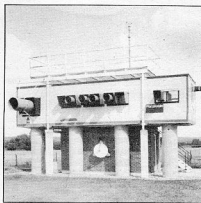

The transmitter cabin at Chilbolton. Hoods keep rain off the windows through which the signals are transmitted. The transmitters are mounted on benches supported independently from ground, inside the four concrete pillars. This prevents vibrations in the cabin affecting the equipment. The anemometer and vane mounted on top of the cabin measure wind velocity.

various phenomena which may affect the reliability of communications systems, and providing the statistical information required by systems designers.

## Two main analyses

The data base is being extensively analysed in two different ways. Detailed studies are being made of individual events, such as particular rain storms, snow storms, fogs and so on, to learn more about the way radio waves propagate through such phenomena. From such studies it will be possible to develop more detailed and accurate theoretical descriptions than so far exist of the way various kinds of precipitation and so forth interact with radio waves. These theoretical models, as they are generally known, can then be used to predict what may happen on proposed new communications links in areas where little, if any, propagation or meteorological data exist. The second mode of analysis is aimed at providing the kind of statistical data necessary for the most cost-effective design of new communications systems, and to provide a statistical data base for testing and validating the prediction techniques being developed.

Analyses based on individual events are classified according to the type of event, for example rain, snow, hail, fog or scintillation. Extensive studies on rain already indicate a general overall agreement both with similar studies conducted elsewhere and the theoretical models which so far exist, such as those recommended by the CCIR. Nevertheless, certain significant differences have been found, which may possibly be attributed to the differences in climate between southern England and the places where other studies have been

made. Understanding such climatological differences is very important in being able to develop prediction models if they are to be applied to any place on Earth. We feel that our work will help considerably in achieving this. Attenuations produced by rain vary considerably, of course, because they depend on the features of the rain. Light drizzle may attenuate the signals by only a few per cent over the 500 m range, whereas intense thunderstorms can attenuate by more than 30 dB km<sup>-1</sup> at 97 GHz, for example; in other words, only 0.1 per cent of the signal remains after a distance of one kilometre. Fortunately, such events are very confined.

## Snow and fog

Of great interest is the effect that snow storms have on millimetre communications. There is shortage of such data and the few results available show wide variations. Snow is generally difficult to characterize quantitatively with regard to shape, size and wetness of the flakes. These characteristics vary widely, and when snow is carried by the wind it becomes difficult even to measure effective deposit rates. However, we have developed a rapid response snow gauge which is producing very encouraging results. The effects of wind are kept as low as possible by surrounding the gauge with a fence, which reduces wind speeds close to the gauge and so improves the efficiency of capture. Using this technique, we find good correlations between attenuation and snowfall deposit rates. Results so far indicate that when snow is very dry the attenuations are low, compared with rain, for the same amount of liquid water deposited; but for wet snow, attenuations can be considerably higher. The attenuation clearly depends not only on the amount of liquid water falling, but also on the degree of wetness of the snow flakes. Considerable effort is being devoted to trying to characterize this in terms of other meteorological parameters such as air temperature, so that empirical relationships can be developed to help the prediction of attenuation.

Fogs, on the other hand, affect the millimetre links very little; the wavelengths are much greater than the size of the water droplets and the scattering process, which causes the attenuation, is not significant. In general, the attenuations found at millimetre wavelengths are only a few per cent at the 500 m range. At infra-red and optical wavelengths, however, very severe attenuations, of more than 80 dB km<sup>-1</sup>, often occur in the visible range in fog, representing a visibility of only about 200 m; only one millionth of one per cent of the signal remains at a distance of one kilometre from the transmitter.

## Gas flares

The 500 m range can easily accommodate a variety of different measurements or experiments from other interested groups, especially as all the instrumentation and the data collection system are based on a universal interface standard. As an example of this, an interesting and novel investigation was carried out into millimetre-wave propagation through flames, in collaboration with one of the oil companies operating in the North Sea. The problem was what effect gas flares on the drilling platforms might have on the communications systems. A large flame was generated, about three metres wide, three metres high and half a metre deep and the signals were transmitted through it. Little effect was observed at the lowest frequencies, though large attenuations occurred in the visible range. There was, however, a general increase in the level of scintillation of the signals, which might possibly be of concern at the very high frequencies but of little significance at the frequencies at present in use for communications systems.

The other type of analysis of results is aimed at obtaining the kind of statistical information needed for direct application to communications systems design, for example finding out what fade margins should be allowed for given levels of operational reliability. This is necessarily a longterm project, because it is important to find an average over extremes of the prevailing meteorology and it can be done reliably only over a number of years. Statistical data now being accumulated include such information as the percentages of time that various levels of attenuation are exceeded, from which fade margins can be directly derived; probability distributions of the duration of fades to yield information on the length of data 'dropouts'; the times between fades, which tell us how often deep fades are likely to occur; and the rate of change of fading, which indicates how rapidly signals are likely to change, which is particularly important in digital radio communications systems. The propagation statistics are complemented by similar statistics of meteorological parameters, especially of rainfall rates. Direct comparison of these two sets of simultaneously obtained data then enables propagation conditions to be predicted simply from rainfall data, which is relatively easy and inexpensive to obtain and is measured routinely by weather bureaux in most countries of the world.

## Future work

The information obtained on the 500 m range will be of immense value in providing propagation statistics and in

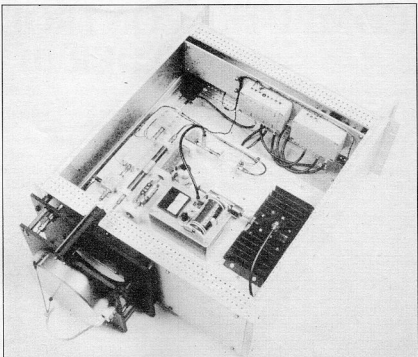

The 97 GHz receiver with its 15 cm diameter antenna and swan-neck waveguide feed. Its solid-state local oscillator is mounted on a heat sink on the right-hand side. A battery-operated power supply biases the receiver's Schottky-barrier mixer to its most sensitive operating region.

developing propagation models and prediction techniques for planning future communications systems. The data is being collected over a relatively short distance, chosen deliberately to ensure that the meteorological conditions would be nearly constant over the range. In general, however, practical communications links operating at millimetre wavelengths will have much greater path lengths, perhaps up to several tens of kilometres or more, depending on the frequency.

It is generally found that precipitation, the dominant source of fading in the millimetre region, is characteristically not homogeneous or uniformly distributed horizontally. Widespread (stratiform) rain is found to contain imbedded convective cells with higher rainfall rates than the surrounding stratiform regions. Such cells tend, on average, to be about 12 km apart and from two to three kilometres in diameter. As a result, it is not practicable simply to scale the data obtained on the 500 m range to path lengths of more than about two kilometres.

To obtain data over the longer paths which would be used in operational millimetre-wavelength communications systems, an additional link is being developed to operate in conjunction with the 500 m range over a path of about seven kilometres. This will provide data on path-length scaling, in which the 500 m data are applied to longer, more

practical link lengths; at the same time it will produce a data base for validating practical prediction techniques. The link will operate at frequencies of 55 GHz, near the peak of the oxygen absorption band, and 95 GHz, in an atmospheric 'window'. These represent two regions of the radio spectrum in which there is considerable interest, for reasons already mentioned, to do with their application to specific types of future communications systems.

These two sets of multi-frequency transmission links, operated simultaneously, will enable us to build up one of the most comprehensive propagation data base for future millimetre-wave terrestrial communications systems design. The detailed and extensive programme of data analysis now going on and being proposed will yield essential information for expanding terrestrial radio communications into the millimetre-wavelength regions of the radio spectrum for the foreseeable future.

# COMPUTER-CONTROLLED SLIDE FADER (1)

Revenge yourself on giggling friends and relatives joined to watch and criticize your clumsy slide presentation.

This project gives the creativity you put in your colour slides an extra dimension in the true sense of the word. A chance for all mindful photographers and slide makers to stun their audience with a dazzling show of fading and dissolving images, sudden or gradual colour changes, the repeating of "theme" slides, and many more special effects, achieved by intelligent control of four slide projectors.

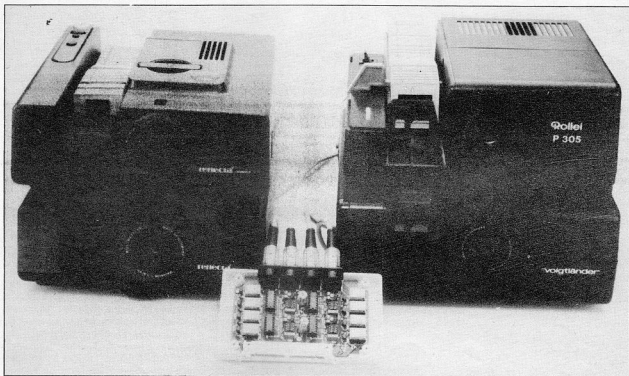

The main difficulty in making a slide presentation is to capture the attention of the audience. Television, the motion picture, and modern advertisement techniques prove beyond doubt that the degree of attention depends strongly on the rate at which the human mind appears to perceive changing images. While appreciating the difference in character and objective between a well-prepared slide presentation and, say, a video clip, the former is often needlessly static. It is, of course, true that this is often useful for educational purposes, where it is required that an image be shown as long as necessary to allow for explanatory comments, but the show soon becomes dreary when pictures are abruptly changed with the operator occasionally forced to go through all the previous ones before he can pick out the slide that requires repeating for additional comment.

The computer controlled slide fader de-

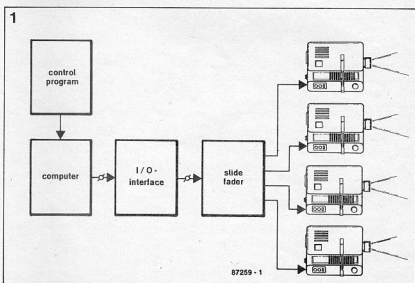

Fig. 1. Functional blocks in the computer-controlled slide fader system.

scribed here is sure to add motion and liveliness to your next slide presentation. The effects that can be obtained with it are in the hands of the operator: in its basic version, the fader enables computer control of the lamp intensity in 64 steps, and the reverse/forward motion of the slide carrier in any one of up to four slide projectors—see Fig. 1. The hardware required for this is relatively simple, and can be extended or simplified to personal needs. The whole slide show can be designed, directed and prepared by programming a computer in BASIC. Each slide projector requires its own 8-bit output port. Not many computers have 4 such outlets, however, and require equipping with extension circuits published, or to be published, in *Elektronics*:

■ **MSX systems:**

32-bit I/O and timer cartridge: *Elektronics* January 1987, p. 53 ff. Controls up to 4 projectors.

■ **6502, 6800 and Z80 based systems:**

Universal I/O bus: *Elektronics*, May 1985, p. 35 ff. 8-bit I/O bus: *Elektronics*, December 1985, p. 20 ff. Controls 1 projector.

■ **IBM PC XT and compatibles:** to be described in a forthcoming issue of *Elektronics*. Controls 4 projectors.

■ **Centronics port:** to be described in a forthcoming issue of *Elektronics*. Controls up to 4 projectors.

**Circuit description of the lamp dimmer**

Slide images can be faded in and out, just like sound, if the intensity of the projector lamp can be controlled in small steps. Figure 2 shows the circuit diagram of 1 of 4 identical dimmers. At the heart of the circuit is the Type TCA280 dimmer chip, whose basic operation is discussed in reference (1). The intensity of the lamp driven by the triac is an inverse, but non-linear, function of the direct control voltage applied to pin 5 of the chip. The minimum value of the input voltage, +2.5 V, gives maximum intensity, while the lamp is quenched at +5 V. Circuitry on board the TCA280A arranges for the perceived lamp intensity to vary gradually in accordance with the change in the applied input voltage.

The dimmer is powered from the available 24 VAC connections on the lamp transformer in the projector. The triac is fitted as an external component to avoid high currents being carried on the PCB. The Types TIC236 and TIC246 are used for lamps of up to 150 W or 250 W, respectively.

**Circuit description of the control interface**

The circuit diagram of Fig. 3 shows 4 identical control channels: one for each projector used. The control information for each channel is obtained from an 8-bit output port (A, B, C, or D). With

reference to the upper channel, A, 6 bits, A0...A5 incl., are used for controlling the lamp intensity at a resolution of 64 (2<sup>6</sup>) steps. The 2 remaining bits, A6 and A7, control the relays for reverse and forward motion of the slide carrier on the projector.

Digital to analogue converter (DAC) IC<sub>1</sub> accepts the 6-bit binary information from the computer, and translates this into a corresponding direct voltage between 0 and +2.5 V on the output, pin 4. The maximum value is derived from a reference voltage source set up around R<sub>7</sub> and 4 series-connected silicon diodes D<sub>1</sub>...D<sub>4</sub> incl. The forward drop on each of these is approximately 0.62 V. When the computer port sends control value 00H, 40H, or 80H to the DAC, all 6 inputs DB0...DB5 incl. on the DAC are pulled low, so that the converted analogue output voltage is 0 V. The maximum value of the output voltage, U<sub>ref</sub> (+2.5 V), is available when all DAC inputs are programmed logic high, i.e., when the computer sends 3FH, 7FH, or BFH (it makes no sense to activate bits 6 and 7 simultaneously).

Opamp IC<sub>2</sub> is set up as an inverting amplifier connected to the output of the DAC. Its function is to invert and shift the analogue output voltage span of 0 to +2.5 V into the corresponding dimmer input span from +5 V down to +2.5 V. The amplification of the opamp is, therefore, -1. With preset P<sub>1</sub> set to the centre of its travel, the voltage at the non-inverting (+) input is +2.5 V. This is the lowest output voltage of the opamp, resulting in maximum illumination of the lamp. The use of the inverting and span shifting opamp facilitates the programming on the computer, since the lowest and highest values sent to the DAC correspond to minimum and maximum illumination of the projector lamp. A preset is used rather than a fixed potential divider to enable optimum matching of the dimmer to the lamp in the associated projector.

Bits 6 and 7 in the byte sent to each channel arrange the forward or reverse motion of the slide carrier via relays Re and Re<sub>r</sub>. The contacts of these form an SPDT switch connected to pins 3 and 5 on the relevant 5-way DIN socket at the output of the controller board. The intensity control signals for the 4 dimmer boards, and the system ground, are also carried via the DIN sockets.

The pin-out on K<sub>5</sub> is in accordance with that on the previously mentioned 32-bit I/O and timer cartridge, so that this connects direct to the 4-way slide controller board. For non-MSX computers, the connection of the slide controller is, unfortunately, a matter of finding the right bits and connections at both ends of the cable.

The 5 V supply for the circuitry on the controller board is obtained from the computer via pins 21 and 22 on K<sub>5</sub>.

2

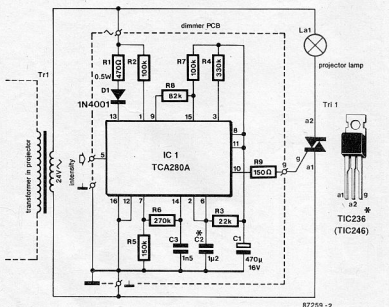
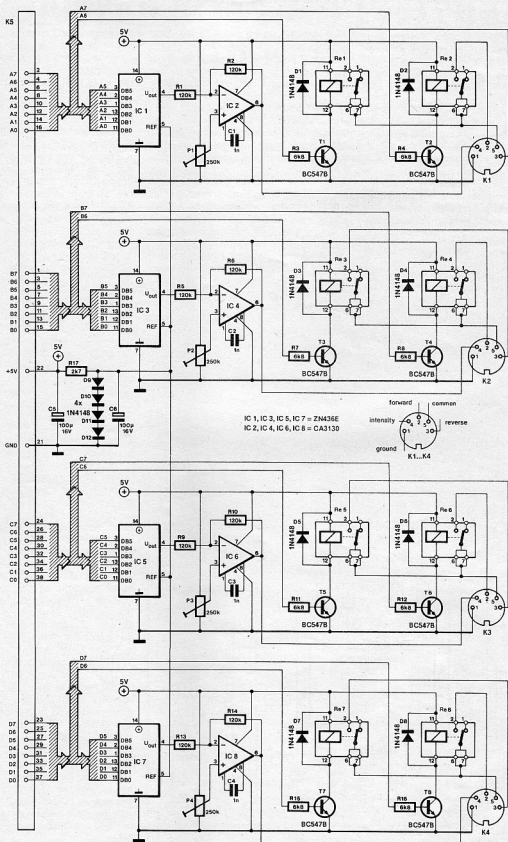

Fig. 2. Circuit diagram of the TCA280 based lamp dimmer.





87259-3

Fig. 3. Circuit diagram of the 4-way computer interface.

#### Parts list

MAIN BOARD (CIRCUIT DIAGRAM: Fig. 3).

#### Resistors ( $\pm 5\%$ ):

R1; R2; R5; R6; R9; R10; R13; R14 = 120K  
R3; R4; R7; R8; R11; R12; R15; R16 = 6k8  
R17 = 2K7  
P1... P4 incl. = 250K or 220K preset H

#### Capacitors:

C1... C4 incl. = 1n0  
C5; C6 = 100 $\mu$ ; 16 V

#### Semiconductors:

D1... D12 incl. = 1N4148  
T1... T8 incl. = BC547B  
IC1; IC3; IC5; IC7 = ZN436E (Ferranti)  
IC2; IC4; IC6; IC8 = CA3130

#### Miscellaneous:

K1... K4 incl. = 5-way angled DIN socket  
(180°) for PCB mounting.  
K5 = 50-way angled header; 2 rows of 25 pins,  
for PCB edge mounting.  
Re1... Res incl. = SPDT relay for PCB mount-  
ing, e.g. Siemens V23101-A0003-B101.  
PCB Type 87259

#### Parts list

DIMMER PCBs (CIRCUIT DIAGRAM: Fig. 2).

#### Resistors ( $\pm 5\%$ ):

R1 = 470R; 0.5 W  
R2; R7 = 100K  
R3 = 23K  
R4 = 330K  
R5 = 150K  
R6 = 270K  
R8 = 82K  
R9 = 150R

#### Capacitors:

C1 = 470 $\mu$ ; 16 V  
C2 = 1 $\mu$ 2 (see text)  
C3 = 1n5

#### Semiconductors:

D1 = 1N4001  
IC1 = TCA280A  
Tri1 = TIC236 or TIC246 (see text)

4

**ATTENTION**

## PCBs & Set of COMPONENTS

for projects are normally available with

**precious**<sup>®</sup> ELECTRONICS CORPORATION

52-C Proctor Road, Bombay-400 007 Phones: 367459/369478

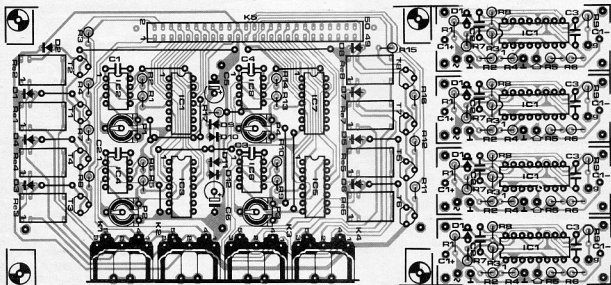

Fig. 4. This PCB is used for building the interface and 4 dimmers.

## Construction: 5 boards in 1

The ready-made printed circuit board of Fig. 4 is cut in 5 pieces to obtain 1 interface board, and 4 dimmer boards.

Commence the construction by populating the dimmer boards according to the component overlay and the parts list. Mount a  $1\mu\text{F}$  and a  $220\text{nF}$  capacitor in parallel if the  $1.2\mu\text{F}$  type in position  $C_2$  is difficult to obtain. Electrolytic capacitor  $C_1$  and triac  $\text{Tri}_1$  are fitted as external components. This enables the triac to be cooled effectively, while avoiding tracks carrying lamp currents of several amperes. The dimmer board and the triac should be mounted in a suitable location inside the slide projector. A metal surface near the fan is, of course, ideal for mounting the triac because it forms a heat-sink (do not forget to insulate the triac with the aid of a mica washer). Figures 5 and 6 illustrate the mounting of the triac and the dimmer board in a slide projector Type Diamator 1500 AF.

In some cases, the existing DIN socket on the slide projector may have to be re-wired in accordance with the pin-out on the socket fitted on the controller board. If this is impossible, or less desirable, it is a relatively simple matter to mount an additional DIN socket for ready connection to the interface. Whatever solution is adopted, be sure to know exactly how the slide carrier control system is actuated externally. In case of doubt, it is recommended to consult the user manual supplied with the projector. Universal 5-way DIN cords as used for audio equipment are perfectly adequate for connecting the slide controller to the projectors.

The completion of the 4-way controller board is straightforward. Note the use of PCB mounted DIN sockets, which make for a compact board, obviating the need for extensive wiring. The unit can be fitted in a suitable ABS enclosure, observing that the intensity span presets,  $P_1 \dots P_4$  incl., are easily accessible for adjustment purposes. Figure 7 shows a suggestion for the front panel lay-out.

## Over to you: software

In principle, all effects in a slide presentation are based on 3 operations, namely visual mixing of slides, arranging the order of the slides, and lamp intensity control. As already stated, the number of possible effects depends solely on the creativity put into the computer program. It is, for example, possible to revert to an early slide in the show by reverse shifting of the slide carrier in projector number 3, whose lamp is turned off, while projectors numbers 1, 2 and 4 are used for the current images. This calls for a software slide counter on each channel to keep track of the slide numbers, and hence the forward/reverse mo-

```
10 SCREEN# : CLS ' ===== TEST PROGRAM FOR SLIDE FADER
20 DEFINT A-Z
30 DIM D(15),C(15),I(15)
40 FOR I=0 TO 3 ' ===== ADDRESS INITIALIZATION
50 A=I*16
60 D(0+I*4)=4+A : D(1+I*4)=5+A : D(2+I*4)=8+A : D(3+I*4)=9+A
70 C(0+I*4)=6+A : C(1+I*4)=7+A : C(2+I*4)=10+A : C(3+I*4)=11+A
80 NEXT
90 ON STOP GOSUB 590 : STOP ON
100 FOR X=0 TO 15 ' ===== START CONDITIONS
110 OUT C(X),255 : OUT C(X),0 : OUT C(X),7 : OUT C(X),3
120 OUT D(X),0
130 I(X)=0
140 NEXT
150 P=0 : X=1
160 ON KEY GOSUB 260,300,340,370,400,430,460,490,520,550
170 FOR I=1 TO 10
180 KEY (I) ON
190 NEXT
200 KEY1,"OFF" : KEY2,"ON" : KEY3,"<" : KEY4,">" : KEY5,"-"
210 KEY6,"PREVIOUS" : KEY7,"NEXT" : KEY8,"STEP-" : KEY9,"STEP+" : KEY10,"RESET"
220 KEY ON
230 LOCATE 10,6 : PRINT"PROJECTOR:";P+1; " " : LOCATE 10,8 :
PRINT"LEVEL:";I(P); " "
240 LOCATE 10,10 : PRINT"STEP SIZE";X; " " : LOCATE 10,12 :
PRINT"CHANGE:";X$; " "
250 GOTO 220
260 ' ===== KEY 1 INTENSITY -
270 I(P)=I(P)-X : IF I(P)<0 THEN I(P)=0
280 OUT D(P),I(P) : X$="-"
290 RETURN
300 ' ===== KEY 2 INTENSITY +
310 I(P)=I(P)+X : IF I(P)>63 THEN I(P)=63
320 OUT D(P),I(P) : X$="+"
330 RETURN
340 ' ===== KEY 3 CHANGE REVERSE
350 OUT D(P),64 : X$="<" : I(P)=0
360 RETURN
370 ' ===== KEY 4 CHANGE FORWARD
380 OUT D(P),128 : X$=">" : I(P)=0
390 RETURN
400 ' ===== KEY 5 CHANGE OFF
410 OUT D(P),0 : X$="0" : I(P)=0
420 RETURN
430 ' ===== KEY 6 PREVIOUS PROJECTOR
440 P=P-1 : IF P<0 THEN P=15
450 RETURN
460 ' ===== KEY 7 NEXT PROJECTOR
470 P=P+1 : IF P>15 THEN P=0
480 RETURN
490 ' ===== KEY 8 REDUCE STEP SIZE
500 X=X-1 : IF X<1 THEN X=1
510 RETURN
520 ' ===== KEY 9 INCREASE STEP SIZE
530 X=X+1 : IF X>63 THEN X=63
540 RETURN
550 ' ===== KEY 10 RESET
560 P=0 : X=1 : X$="-"
570 FOR I=0 TO 15: OUT D(I),0 : I(I)=0 : NEXT
580 RETURN
590 ' ===== STOP ROUTINE
600 FOR I=0 TO 15: OUT D(I),0 : NEXT
610 DEFUSR=4H3E : A=USR(0)
620 CLS : END
```

Table 1. MSX BASIC test program for the slide fader.

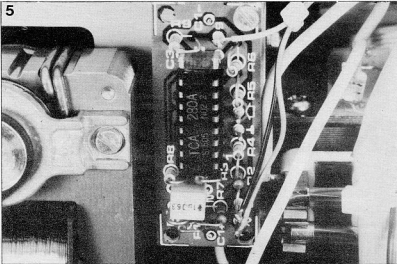

Fig. 5. The dimmer board fitted next to the fan motor in a slide projector. C1 is mounted at the track side of the PCB.

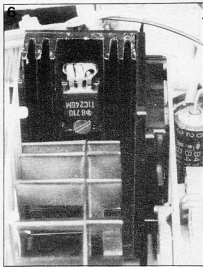

Fig. 6. An ideal location for the hot triac. Some filing is required to fit the heat-sink between the sides of the fan enclosure.

tion of the carrier. A library of routines can be written for fade-in and fade-out effects timed by the CTC (counter/timer controller) on the MSX I/O & timer board.

Programmers should have little difficulty spotting and adapting the slide controller routines in the test program of Table 1. This program runs on MSX computers fitted with at least one I/O & timer cartridge. Part 2 of this article will detail the use of 4 cartridges, so that the same program tests and controls a maximum of 16 projector channels.

Non-MSX users will find lines 260 up to and including 580 useful for analysing the ways in which the test program controls the interface. The instructions in lines 220, 230, 240 and 250 are executed in a loop. The ON KEY GOSUB statement does not form part of this because the function keys on an MSX computer can be programmed to call the relevant subroutine after generating an interrupt (see line 160).

Key the program into the computer, and familiarize yourself with the functions assigned to the function keys. Select a projector, and quench the lamp by holding down the INTENSITY - key. Then adjust the relevant preset on the controller board such that the lamp just about lights. This setting guarantees fast response to software-controlled intensity variations while lengthening the useful life of the lamp.

Some projectors have single-key slide carrier control. This can be simulated by the interface board if the software ensures the correct duration of the forward and reverse pulses. Although it would be possible to omit 1 relay on the board, this is not recommended because it makes the controller less versatile. A better solution in this case is the connection of pins 2 and 3 on the socket internal to the projector in question.

The subject of software for the slide fader will be reverted to in part 2 of this article. We will then discuss an advanced effects program for no fewer than 16 projectors.

R

#### References:

- (1) Halogen lamp dimmer. *Elektron India* September 1987.
- (2) Articles on MSX extensions in *Elektron India*:

I/O bus, digitizer and 8-bit I/O bus: January 1986, p. 66 ff.  
 Cartridge board. February 1986, p. 32 ff.;  
 Add-on bus board. March 1986, p. 55 ff.;  
 Bus direction add-on for MSX extensions. July/August 1987, Supplement p. 52.

Please refer to *Past Articles* on the Readers Services page in this issue.

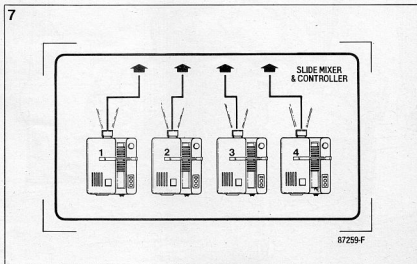

Fig. 7. Suggested front panel lay-out.

# TORMENTOR

The pranks comitted by the young devils are probably as old as the human race itself. In the course of time only the ways and means have changed. The electronics age must also have its effect on these pranks. If one puts a living spider or a frog in the bed of an unfavourite aunt, it will certainly achieve the desired result even in this electronics age. The placing of an electronic animal in the bedroom is not only modern, but it also contributes to the

protection and conservation of the animal world.

An ingenious circuit provided here for this purpose, called the "TORMENTOR" is capable of causing enough harassment. It very closely imitates the noise of a fly or a cricket. Hiding in the bedroom, the tormentor starts making the noise as soon as the lights are switched off. Angry about the nuisance, the target would probably switch on the

bedroom lights again, in order to search for the cause of this vile action. However, the tormentor immediately becomes silent. After a search in vain, as the lights are switched off again, the nuisance starts all over again. The electronic tormentor is really a genuine night animal.

## CIRCUIT:

Figure 2 shows the circuit diagram of our tormentor. The "EYE" of the tormentor is

an LDR (Light Dependent Resistor). The value of an LDR drops as the light increases and becomes very high in darkness. The LDR and the trimpot P1 form a voltage divider, with a ratio dependent on the light conditions. The voltage of this potential divider reaches over R1 to the input of the NAND gate N1. The combination of gates N1 and N2 functions as a schmitt-trigger, as the output signal of N2 is fed back to the input of N1 over the resistor R2.

If the voltage at the junction of the LDR and the trimpot falls below a certain value, then effectively N1 goes from logical 1 to logical 0 value at the input. Output of N1 goes to logical 1 and the output of N2 goes to logical 0, which is in turn connected to the input of N1 over R2.

A rise in the voltage at the junction of the LDR and trimpot switches the output of N2 from logical 0 to logical 1 in a similar fashion.

When the bedroom lights are on, the LDR resistance is low and this makes the transistor T1 conduct. When the lights are switched off, T1 is blocked. When T1 conducts, the capacitor C1 discharges through T1, when T1 is blocked C1 charges over resistor R5. The second schmitt-trigger consisting of N3, N4 and R7 controls the tone generator made of 555 IC. The tone generator is further connected to the loudspeaker.

The capacity of C1 decides the time, which passes from the switching off of the bedroom lights till the tormentor starts showing the signs of life. The nuisance

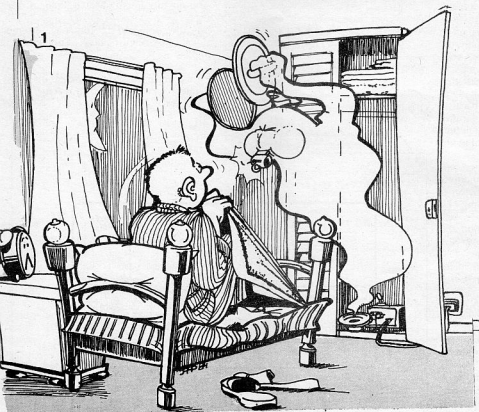
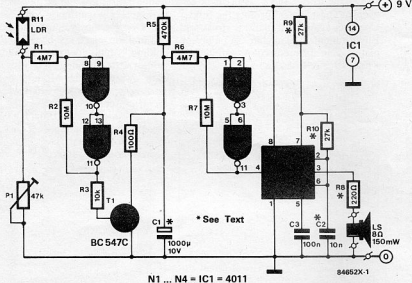

Figure 1:  
The "TORMENTOR" and the target of harassment.

2



value depends on C2 and the ratio of resistance values of R9/R10. The volume is decided by R8.

### CONSTRUCTION:

The "TORMENTOR" can easily fit onto a small SELEX PCB of size 1. The component layout is shown in figure 3 and the completed circuit in figure 4. The LDR can be directly mounted on the PCB as shown in the photograph. It can also be connected over a two core wire, which is not too long. This may make it a bit easier to hide the tormentor with the LDR still exposed to the bedroom light. The maximum length that can work should be decided by trial.

The trimpot can be adjusted to set the desired voltage level at the junction of LDR and the trimpot in such a way that the circuit starts functioning when the bedroom lights are switched off but stops functioning when they are switched on.

One final tip: The success of the tormentor depends on how nicely you are able to hide it. However, Elektor takes no responsibility of the consequences of the use of this tormentor! Use it at your own risk.

3

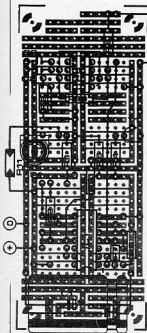

#### Parts List:

- R1, R6 = 4.7 M $\Omega$
- R2, R7 = 10 M $\Omega$
- R3 = 10 K $\Omega$
- R4 = 100 $\Omega$
- R5 = 470 K $\Omega$
- R8 = 220 $\Omega$
- R9, R10 = 27 K $\Omega$
- R11 = LDR
- P1 = 47 K $\Omega$  Trimpot
- C1 = 1000  $\mu$ F/10V
- C2 = 10 nF
- C3 = 100 nF
- T1 = BC 547 C
- IC1 = 4011
- IC2 = 555
- LS = Loud Speaker 8 $\Omega$ /250 mW
- 9 V Battery

Figure 2:

Circuit of the tormentor, Guaranteed anger at a low cost!

Figure 3:

Component layout and wiring diagram,

Figure 4:

The ready to use tormentor - the night ghost in the electronic robe!

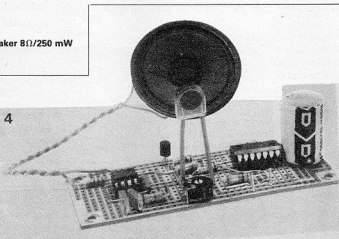

# NEW PRODUCTS • NEW PRODUCTS • N

## Wattmeter

Economy's Digital Wattmeter Uses LSI chips to achieve accuracy. It is also protected against load transients. It is used in many industries where measurement and control of power plays important role like heaters, furnaces and appliances manufacturing units. This instrument has various features such as Direct Digital Display of values & Sunlight visible LED display.



M/s. Economy Electronics • 15 Sweet Home • Plot No. 442 • 2nd floor • Pitamber Lane • Off Tulsī Pipe Road • Mahim • Bombay-400 016.

## PCB Mounting Connectors

IEC have now introduced New PCB Mounting Connectors with 5 mm pitch.

These Printed Circuit Board Mounting Connectors are moulded in Nylon 6 and manufactured in 2/3 way lengths. They are designed to interlock together so that any length of connector can be built up. They accept side entry conductors upto 4 mm<sup>2</sup>.

Although in their standard form they are unmarked, the facility is provided to enable individual marking of terminals with press-in markers.

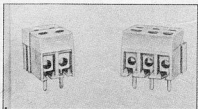

Asia Electric Company • Katara Mansion, • 132 A Dr. A Besant Road • Worli • Bombay-400 018.

## Dust Covers

G.H. INDUSTRIES Introduces "DUST COVERS" for 25 Pin & 9 Pin "D" Connector. These covers protect the Solder Contacts against mechanical stress and Environment. Available in Chrome plated & in different colors-Grey, Pale white, Blue & Black.

Hardware accessories are provided along with covers for fixing "D" Connector along with cable.



G.H. Industries • 84-B Government Industrial Estate • Kandivli • Bombay-400 067.

## Universal Controller

The Universal Controller Micro Mac - 6000 from Analog Devices Inc is a programmable system which interfaces to the real world via single channel signal conditioning modules.

Unlike PLCs and Loop Controllers, Micro Mac - 6000 can direct more complex strategies because it is not limited to ladder logic and does not require add on signal conditioning solutions.

Optimised for Analog I/O Micro Mac-6000 supports 56 analog and 256 digital I/O points.

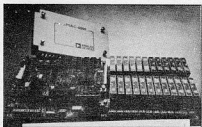

Murugappa Electronics Limited, • 'Parry House' • Third floor • 43, Moore Street • Madras-600 001. • Phone: 27531, 21003, 21019.

## Data Scanner

This instrument is used for monitoring temperature, voltage or any other vital parameters in continuous process industry. One can programme data for each channel through a key board. It has a 24 column dual colour alphanumeric printer with re-rolling facility for logging data with real time. Modular construction using standard bus PCBs has been incorporated to minimize wiring and reducing servicing down time. EEPROM's have been used for a storage of programmed data. Re-chargeable back-up has been provided for the real time clock.

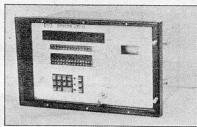

Advani-Oerlikon Ltd. • Post Box No. 1546 • Bombay-400 001.

## Bread Board

Prem Plastics have introduced Solderless Breadboards which are ideal as educational teaching aids and a tool for designing electronic circuits.

The Breadboard can be combined into any required size with combinations of terminal strips and distribution strips. Various models are available. The spring clips are made of Phosphor Bronze and can accept wire of 20-29 AWG (0.03 to 0.08 mm) in all DAP sizes.

ICs, Diodes, Resistors, Capacitors, Transistors and more can be plugged right into the Socket and/or strip.

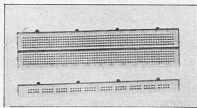

Prem Plastics • 9, Bharat Industrial Estate • T.J. Road • Sewree • Bombay-400 015.

# NEW PRODUCTS • NEW PRODUCTS • N

## CPU Connectors

G.H. INDUSTRIES Introduces CPU CONNECTORS manufactured Indigenously. It consists of Male Headers and Female Connectors harnessed with 23/36 gauge wires with different wire lengths. The Male Headers Pins are 1.14 X 1.14 mm square with 3.96 mm pitch.

CPU Connectors are available in 2, 3, 4, 5, 6, 7, 8, 9, 10, 11 & 12 ways. Used in Computer Power Systems, Instrumentation & Control, Telecommunication. EPABX give power Connections.

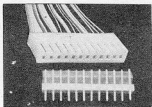

G.H. Industries • 84-B, Government Industrial Estate • Kandivli (West) • Bombay-400 067. • Tel.: 6050097.

## Tester

Equilab model TP-78 is designed for quick checks of electronic components for open/leaky condition, identification of type, gain matching, and electrical continuity. It requires two small cells for operation current drain is less than 10 mA when in operation, therefore safe for semi conductor junction. Basic price Rs. 60/-.

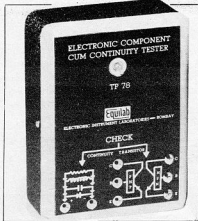

Electronic Instrument Laboratories • B 69/004 Anand Nagar • Chhatrapati Shivaji Road • Dahisar (East) • Bombay-400 068.

## Temperature Indicator

HOSHAKUN offers a Digital Temperature Indicator with 25 mm LED Display thereby extending the viewing distance.

Ranges available are from -200° C. to +1200° C. with suitable sensor like Cr/Al. Fe/Const. thermocouple or PRT Bulbs. Automatic ambient temperature compensation and broken sensors indication are incorporated. The instrument is 230 Volts A.C. mains operated. The instrument size confirms to DIN standard panel cutout.

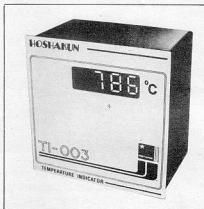

Hoshakun • Vivek Apartments • Plot No. 15 • Tulshibagwale colony • Saharkarnagar No. 2 • Pune-411 009.

## Insulation Tester

Economy's Digital Insulation Tester has 3 fundamental features,

- 1) It measures the insulation properties on two different ranges, VIZ 20 M OHM & 2000 M OHM.
- 2) Resistance is measured in 5 ranges Viz 200 Ohms, 2, 20, 200 and 2 M OHM.
- 3) The instrument is measured the line voltage if the probes are connected to the AC supply up to 1000 Volts.

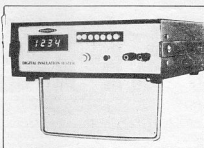

M/s. Economy Electronics • 15, Sweet Home • Plot No. 442, • 2nd floor • Pitamber Lane • Off Tulsi Pipe Road • Mahim • Bombay-400 016.

## Computer Development System

Professional Electronic Products has introduced an advanced 16/32 Bit Single Board Computer/Development System, SBC-68K-I, designed for training and development. Features include MC 68000 CPU operating at 8MHz, 24K bytes of powerful EPROM monitor including single line assembler/disassembler 128 K dynamic RAM, two RS232C serial ports for connection to CRT Terminal and host computer, on board CRT controller (6845), 24-bit programmable timer, 16 + 24 parallel I/O lines, on board audio cassettes interface, on-board EPROM programmer for programming 2716 to 27256 EPROMs and HN 48016 EPROMs, optional 68000 macro cross assembler to run on any IBM PC compatible.

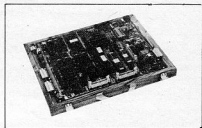

Professional Electronic Products • PB 316 Delhi Road • Opp Old Octroi Post • Meerut • Uttar Pradesh 250 002.

## Machine Screws

PIC offers a very wide and comprehensive range of Machine Screws for almost all applications.



Precision Industrial Components • 15 Elcheewala Bldg. • 2nd Floor • 11 Keshavji Naik Road • above Corp Bank • Bombay-400 009



# Your Right Connection... Champion

## The Champion Connectors!

- o Dual In-line IC Sockets.
- o Single In-line IC Sockets.
- o Pin Grid Array Sockets.
- o Socket Adaptors.
- o Cage Jacks.

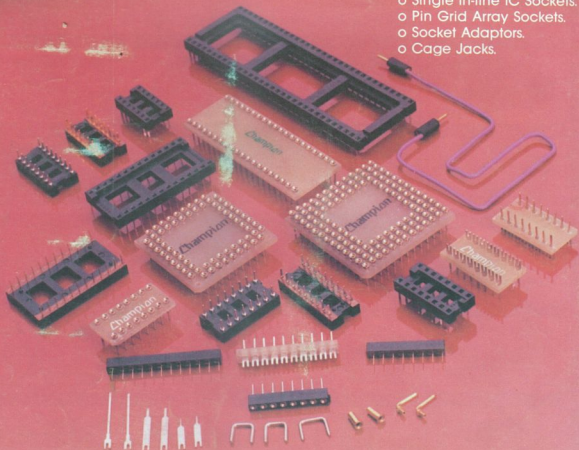

**Champion Electronics Pvt. Ltd.**

S-17, M.I.D.C. Bhosari, Pune 411 026, India. (0212) 82682, 83791 Cable : CHAMPION  
Telex: 0146-343 CHMP IN. 0145-333 MCCI IN. 0145-505 MCCI IN.